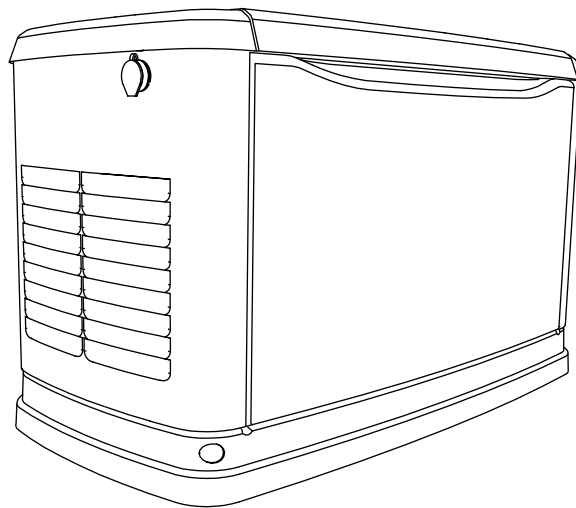

# Owner's Manual

## 60 Hz Air-Cooled Generators

15 kW EcoGen™

**WARNING**

Loss of life. This product is not intended to be used in a critical life support application. Failure to adhere to this warning could result in death or serious injury. (000209b)

Register your Generac product at:  
[WWW.GENERAC.COM](http://WWW.GENERAC.COM)  
1-888-GENERAC  
(888-436-3722)

Para español, visita: <http://www.generac.com/service-support/product-support-lookup>

Pour le français, visiter : <http://www.generac.com/service-support/product-support-lookup>

**SAVE THIS MANUAL FOR FUTURE REFERENCE**

**Use this page to record important information about this generator set.**

Model:	
Serial:	
Production Date:	
Volts:	
LPV Amps:	
NG Amps:	
Hz:	
Phase:	
Controller P/N:	
STA MAC ID:	
SSID:	

Record the information found on the unit data label on this page. See **General Information** for the location of the unit data label. The unit has a label plate affixed to the inside partition, to the left of the control panel console as shown in **Figure 2-1**. See **Operation** for directions on how to open the top lid and remove the front panel.

Always supply the complete model and serial numbers of the unit when contacting an Independent Authorized Service Dealer (IASD) about parts and service.

**Operation and Maintenance:** Correct maintenance and care of the unit ensures a minimum number of problems, and keeps operating expenses at a minimum. It is the operator's responsibility to perform all safety inspections, to verify all maintenance for safe operation is performed promptly, and to have the equipment inspected periodically by an IASD. Normal maintenance, service, and replacement of parts are the responsibility of the owner/operator and are not considered defects in materials or workmanship within the terms of the warranty. Individual operating habits and usage may contribute to the need for additional maintenance or service.

When the generator requires servicing or repairs, Generac recommends contacting an IASD for assistance. Authorized service technicians are factory-trained and are capable of handling all service needs. To locate the nearest IASD, please visit the dealer locator at: [www.generac.com/Dealer-Locator](http://www.generac.com/Dealer-Locator).

 <b>WARNING</b> <b>CANCER AND REPRODUCTIVE HARM</b> <a href="http://www.P65Warnings.ca.gov">www.P65Warnings.ca.gov</a> (000393a)
--

# Table of Contents

## **Section 1: Safety Information**

<b>Introduction</b> .....	<b>1</b>
Read This Manual Thoroughly .....	1
<b>Safety Rules</b> .....	<b>1</b>
How to Obtain Service .....	2
<b>General Hazards</b> .....	<b>2</b>
<b>Exhaust Hazards</b> .....	<b>3</b>
<b>Electrical Hazards</b> .....	<b>3</b>
<b>Fire Hazards</b> .....	<b>3</b>
<b>Explosion Hazards</b> .....	<b>4</b>
<b>Battery Hazards</b> .....	<b>4</b>

## **Section 2: General Information**

<b>EcoGen Theory of Operation</b> .....	<b>7</b>
<b>Generator Components and Locations</b> .....	<b>8</b>
<b>Data Decals</b> .....	<b>9</b>
<b>Specifications</b> .....	<b>10</b>
Generator .....	10
Engine .....	10
<b>Protection Systems</b> .....	<b>11</b>
<b>Emissions</b> .....	<b>11</b>
<b>Fuel Requirements</b> .....	<b>11</b>
<b>Battery Requirements</b> .....	<b>11</b>
<b>Engine Oil Requirements</b> .....	<b>11</b>
<b>Activating the Generator</b> .....	<b>11</b>
<b>Wi-Fi Module</b> .....	<b>12</b>
<b>Replacement Parts</b> .....	<b>12</b>
<b>Accessories</b> .....	<b>12</b>

## **Section 3: Operation**

<b>Site Prep Verification</b> .....	<b>13</b>
<b>Generator Enclosure</b> .....	<b>13</b>
Opening the Lid .....	13
Front Access Panel Removal .....	13
Intake Side Panel Removal .....	14
<b>Main Line Circuit Breaker (Generator Disconnect)</b> .....	<b>14</b>
<b>LED Indicator Lights</b> .....	<b>14</b>
<b>Generator Emergency Shutdown Switch</b> .....	<b>15</b>

<b>Control Panel Interface</b> .....	<b>15</b>
<b>Using the AUTO/OFF/MANUAL Buttons</b> .....	<b>15</b>
<b>Operating Modes</b> .....	<b>16</b>
<b>Interface Menu Displays</b> .....	<b>16</b>
LCD Panel .....	16
Menu System Navigation .....	17
<b>Setting the Exercise Timer</b> .....	<b>19</b>
<b>Battery Charger</b> .....	<b>19</b>
<b>Two-Wire Start Signal and Off-Grid Mode Enabled</b> .....	<b>19</b>
<b>Manual Transfer Operation (if equipped)</b> .....	<b>20</b>
Transfer to Generator Power Source .....	20
Transfer to Utility Power Source .....	20
<b>Automatic Transfer Operation</b> .....	<b>20</b>
<b>Automatic Sequence of Operation</b> .....	<b>20</b>
Utility Failure (if equipped with Transfer Switch and Off-Grid Mode Disabled) .....	20
Cranking .....	21
Cold Smart Start .....	21
Load Transfer .....	21
<b>Shutting Generator Down While Under Load or During a Utility Outage</b> .....	<b>21</b>

## **Section 4: Maintenance**

<b>Maintenance</b> .....	<b>23</b>
<b>Preparing for Maintenance</b> .....	<b>23</b>
<b>Performing Scheduled Maintenance</b> .....	<b>23</b>
<b>Service Schedule</b> .....	<b>24</b>
<b>Maintenance Log</b> .....	<b>24</b>
<b>Checking Engine Oil Level</b> .....	<b>25</b>
Engine Oil Requirements .....	25
<b>Changing Oil and Oil Filter</b> .....	<b>26</b>
Oil System Drain Pump Kit Parts List .....	26
Assembling Oil System Drain Pump .....	26
EcoGen Oil Change Procedure .....	27
<b>Replacing Engine Air Filter</b> .....	<b>28</b>
<b>Spark Plugs</b> .....	<b>28</b>
<b>Valve Clearance Adjustment</b> .....	<b>29</b>
Checking Valve Clearance .....	29
Adjust Valve Clearance .....	29

<b>Battery Maintenance</b> .....	<b>29</b>
Inspecting the Battery .....	30
<b>Cleaning the Sediment Trap</b> .....	<b>31</b>
<b>Post Maintenance Checks</b> .....	<b>31</b>
Performing Fuel System Leak Test .....	31
<b>Attention After Submersion</b> .....	<b>32</b>
<b>Corrosion Protection</b> .....	<b>32</b>
<b>Remove From, and Return To Service Procedure</b> .....	<b>32</b>
Remove From Service .....	32
Return to Service .....	32
 <b><i>Section 5: Troubleshooting / Quick Reference Guide</i></b>	
<b>Generator Troubleshooting</b> .....	<b>33</b>
<b>Quick Reference Guide</b> .....	<b>35</b>

# Section 1: Safety Information

## Introduction

Thank you for purchasing this compact, high performance, air-cooled, engine-driven generator. In off-grid applications as part of an alternative energy system, the generator starts when the inverter or battery charger detects the normal power source voltage has dropped below a preset level. The generator powers the inverter and, once battery voltage rises to an acceptable level, the generator shuts down. Another off-grid application may be for use in remote locations where the generator powers a water pump for a village, campground, or live-stock.

This unit is factory installed in an all-weather, metal enclosure intended exclusively for outdoor installation. This generator will operate using either vapor withdrawn liquid propane (LP) or natural gas (NG).

**NOTE:** When sized correctly, this generator is suitable for supplying typical residential loads such as induction motors (sump pumps, refrigerators, air conditioners, furnaces, etc.), electronic components (computer, monitor, TV, etc.), lighting loads, and microwaves. This unit is also equipped with a Wi-Fi<sup>®</sup> module, which allows the generator owner to monitor generator status from anywhere they have Internet access.

**NOTE:** Wi-Fi<sup>®</sup> is a registered trademark of Wi-Fi Alliance<sup>®</sup>.

The information in this manual is accurate based on products produced at the time of publication. The manufacturer reserves the right to make technical updates, corrections, and product revisions at any time without notice.

## Read This Manual Thoroughly



Consult Manual. Read and understand manual completely before using product. Failure to completely understand manual and product could result in death or serious injury. (000100a)

If any section of this manual is not understood, contact the nearest Independent Authorized Service Dealer (IASD) or Generac Customer Service at 1-888-436-3722 (1-888-GENERAC), or visit [www.generac.com](http://www.generac.com) for starting, operating, and servicing procedures. The owner is responsible for correct maintenance and safe use of the unit.

This manual must be used in conjunction with all other supporting product documentation supplied with the product.

SAVE THESE INSTRUCTIONS for future reference. This manual contains important instructions that must be followed during placement, operation, and maintenance of the unit and its components. Always supply this manual to any individual that will use this unit, and instruct them on how to correctly start, operate, and stop the unit in case of emergency.

## Safety Rules

The manufacturer cannot anticipate every possible circumstance that might involve a hazard. The alerts in this manual, and on tags and decals affixed to the unit, are not all inclusive. If using a procedure, work method, or operating technique that the manufacturer does not specifically recommend, verify that it is safe for others and does not render the equipment unsafe.

Throughout this publication, and on tags and decals affixed to the unit, DANGER, WARNING, CAUTION, and NOTE blocks are used to alert personnel to special instructions about a particular operation that may be hazardous if performed incorrectly or carelessly. Observe them carefully. Alert definitions are as follows:



Indicates a hazardous situation which, if not avoided, will result in death or serious injury.

(000001)



Indicates a hazardous situation which, if not avoided, could result in death or serious injury.

(000002)



Indicates a hazardous situation which, if not avoided, could result in minor or moderate injury.

(000003)

**NOTE:** Notes contain additional information important to a procedure and will be found within the regular text of this manual.

These safety alerts cannot eliminate the hazards that they indicate. Common sense and strict compliance with the special instructions while performing the action or service are essential to preventing accidents.

## How to Obtain Service

Contact an IASD for assistance when the generator requires servicing or repairs. Service technicians are factory-trained and are capable of handling all service needs. Please visit the dealer locator at: [www.generac.com/Service/DealerLocator/](http://www.generac.com/Service/DealerLocator/) to locate the nearest IASD.

When contacting a dealer about parts and service, always supply the complete model and serial numbers of the unit as given on its data plate (decal), which is located on the generator. See *Figure 2-1* for decal location. Record the model and serial numbers in the spaces provided on the inside front cover of this manual.

## General Hazards

### **⚠ DANGER**

Loss of life. Property damage. Installation must always comply with applicable codes, standards, laws and regulations. Failure to do so will result in death or serious injury. (000190)

### **⚠ DANGER**

Automatic start-up. Disconnect utility power and render unit inoperable before working on unit. Failure to do so will result in death or serious injury. (000191)



### **⚠ WARNING**

Loss of life. This product is not intended to be used in a critical life support application. Failure to adhere to this warning could result in death or serious injury. (000209b)

### **⚠ WARNING**

Equipment damage. This unit is not intended for use as a prime power source. It is intended for use as an intermediate power supply in the event of temporary power outage only. Doing so could result in death, serious injury, and equipment damage. (000247a)

### **⚠ WARNING**

Accidental Start-up. Disconnect the negative battery cable, then the positive battery cable when working on unit. Failure to do so could result in death or serious injury. (000130)

### **⚠ WARNING**

Equipment damage. Only qualified service personnel may install, operate, and maintain this equipment. Failure to follow proper installation requirements could result in death, serious injury, and equipment or property damage. (000182a)



### **⚠ WARNING**

Electrocution. Potentially lethal voltages are generated by this equipment. Render the equipment safe before attempting repairs or maintenance. Failure to do so could result in death or serious injury. (000187)

### **⚠ WARNING**

Electric shock. Only a trained and licensed electrician should perform wiring and connections to unit. Failure to follow proper installation requirements could result in death, serious injury, and equipment or property damage. (000155a)



### **⚠ WARNING**

Moving Parts. Do not wear jewelry when starting or operating this product. Wearing jewelry while starting or operating this product could result in death or serious injury. (000115)



### **⚠ WARNING**

Moving Parts. Keep clothing, hair, and appendages away from moving parts. Failure to do so could result in death or serious injury. (000111)



### **⚠ WARNING**

Hot Surfaces. When operating machine, do not touch hot surfaces. Keep machine away from combustibles during use. Hot surfaces could result in severe burns or fire. (000108)

### **⚠ WARNING**

Equipment and property damage. Do not alter construction of, installation, or block ventilation for generator. Failure to do so could result in unsafe operation or damage to the generator. (000146)

### **⚠ WARNING**

Risk of injury. Do not operate or service this machine if not fully alert. Fatigue can impair the ability to operate or service this equipment and could result in death or serious injury. (000215a)

### **⚠ WARNING**

Environmental Hazard. Always recycle batteries at an official recycling center in accordance with all local laws and regulations. Failure to do so could result in environmental damage, death, or serious injury. (000228)

**⚠ WARNING**

Injury and equipment damage. Do not use generator as a step. Doing so could result in falling, damaged parts, unsafe equipment operation, and could result in death or serious injury. (000216)

- Inspect the generator regularly, and contact the nearest IASD for parts needing repair or replacement.

**Exhaust Hazards**



**⚠ DANGER**

Asphyxiation. Running engines produce carbon monoxide, a colorless, odorless, poisonous gas. Carbon monoxide, if not avoided, will result in death or serious injury. (000103)



**⚠ WARNING**

Asphyxiation. Always use a battery operated carbon monoxide alarm indoors and installed according to the manufacturer's instructions. Failure to do so could result in death or serious injury. (000178a)

**⚠ WARNING**

Equipment and property damage. Do not alter construction of, installation, or block ventilation for generator. Failure to do so could result in unsafe operation or damage to the generator. (000146)



**⚠ WARNING**

Fire risk. Fuel and vapors are extremely flammable. Do not operate indoors. Doing so could result in death, serious injury, or property or equipment damage. (000281)

- The generator must be installed and operated outdoors only.

**Electrical Hazards**



**⚠ DANGER**

Electrocution. Contact with bare wires, terminals, and connections while generator is running will result in death or serious injury. (000144)



**⚠ DANGER**

Electrocution. Never connect this unit to the electrical system of any building unless a licensed electrician has installed an approved transfer switch. Failure to do so will result in death or serious injury. (000150)

**⚠ DANGER**

Electrical backfeed. Use only approved switchgear to isolate generator from the normal power source. Failure to do so will result in death, serious injury, and equipment damage. (000237)



**⚠ DANGER**

Electrocution. Verify electrical system is properly grounded before applying power. Failure to do so will result in death or serious injury. (000152)



**⚠ DANGER**

Electrocution. Do not wear jewelry while working on this equipment. Doing so will result in death or serious injury. (000188)



**⚠ DANGER**

Electrocution. Water contact with a power source, if not avoided, will result in death or serious injury. (000104)



**⚠ DANGER**

Electrocution. In the event of electrical accident, immediately shut power OFF. Use non-conductive implements to free victim from live conductor. Apply first aid and get medical help. Failure to do so will result in death or serious injury. (000145)

**Fire Hazards**



**⚠ WARNING**

Fire hazard. Do not obstruct cooling and ventilating airflow around the generator. Inadequate ventilation could result in fire hazard, possible equipment damage, death or serious injury. (000217)



**⚠ WARNING**

Fire and explosion. Installation must comply with all local, state, and national electrical building codes. Noncompliance could result in unsafe operation, equipment damage, death, or serious injury. (000218)



**⚠ WARNING**

Consult Manual. Read and understand manual completely before using product. Failure to completely understand manual and product could result in death or serious injury. (000100a)



**⚠ WARNING**

Electrocution. Refer to local codes and standards for safety equipment required when working with a live electrical system. Failure to use required safety equipment could result in death or serious injury. (000257)



**⚠ WARNING**

Risk of Fire. Unit must be positioned in a manner that prevents combustible material accumulation underneath. Failure to do so could result in death or serious injury. (000147)

Comply with regulations the Occupational Safety and Health Administration (OSHA) has established, or with equivalent standards. Also, verify that the unit is applied, used, and maintained in accordance with the manufacturer's instructions and recommendations. Do nothing that might alter safe application/usage and render the unit in noncompliance with the aforementioned codes, standards, laws, and regulations.

## Explosion Hazards



**⚠ DANGER**

Explosion and fire. Fuel and vapors are extremely flammable and explosive. No leakage of fuel is permitted. Keep fire and spark away. Failure to do so will result in death or serious injury. (000192)

**⚠ DANGER**

Explosion and fire. Connection of fuel source must be completed by a qualified professional technician or contractor. Incorrect installation of this unit will result in death, serious injury, and property and equipment damage. (000151a)



**⚠ DANGER**

Risk of fire. Allow fuel spills to completely dry before starting engine. Failure to do so will result in death or serious injury. (000174)



**⚠ WARNING**

Risk of Fire. Hot surfaces could ignite combustibles, resulting in fire. Fire could result in death or serious injury. (000110)

## Battery Hazards



**⚠ DANGER**

Electrocution. Do not wear jewelry while working on this equipment. Doing so will result in death or serious injury. (000188)



**⚠ WARNING**

Explosion. Do not dispose of batteries in a fire. Batteries are explosive. Electrolyte solution can cause burns and blindness. If electrolyte contacts skin or eyes, flush with water and seek immediate medical attention. (000162)



**⚠ WARNING**

Explosion. Batteries emit explosive gases while charging. Keep fire and spark away. Wear protective gear when working with batteries. Failure to do so could result in death or serious injury. (000137a)



**⚠ WARNING**

Electrical shock. Disconnect battery ground terminal before working on battery or battery wires. Failure to do so could result in death or serious injury. (000164)



**⚠ WARNING**

Risk of burns. Batteries contain sulfuric acid and can cause severe chemical burns. Wear protective gear when working with batteries. Failure to do so could result in death or serious injury. (000138a)

**⚠ WARNING**

Risk of burn. Do not open or mutilate batteries. Batteries contain electrolyte solution which can cause burns and blindness. If electrolyte contacts skin or eyes, flush with water and seek immediate medical attention. (000163a)

---

**⚠ WARNING**

Environmental Hazard. Always recycle batteries at an official recycling center in accordance with all local laws and regulations. Failure to do so could result in environmental damage, death, or serious injury. (000228)

---

Always recycle batteries in accordance with local laws and regulations. Contact your local solid waste collection site or recycling facility to obtain information on local recycling processes. For more information on battery recycling, visit the Battery Council International website at: <http://batteryCouncil.org>.

**This page intentionally left blank.**

## *Section 2: General Information*

### **EcoGen Theory of Operation**

In an off-grid solution, the generator is an important source of backup power when other resources are insufficient for the demand, improving overall system reliability.

1. Solar cells and/or wind turbines generate DC current.
2. DC current is fed to the inverter charger and then to the battery bank.
3. The inverter takes DC power from the battery bank, converts it to AC, and then sends the current to the AC electrical panel.
4. If there is no solar or wind gain and the battery bank level drops below a preset threshold, the inverter automatically signals the generator to start.
5. The generator feeds AC power to the inverter, which in turn sends power to the electric panel and recharges the battery bank to an acceptable level.

## Generator Components and Locations

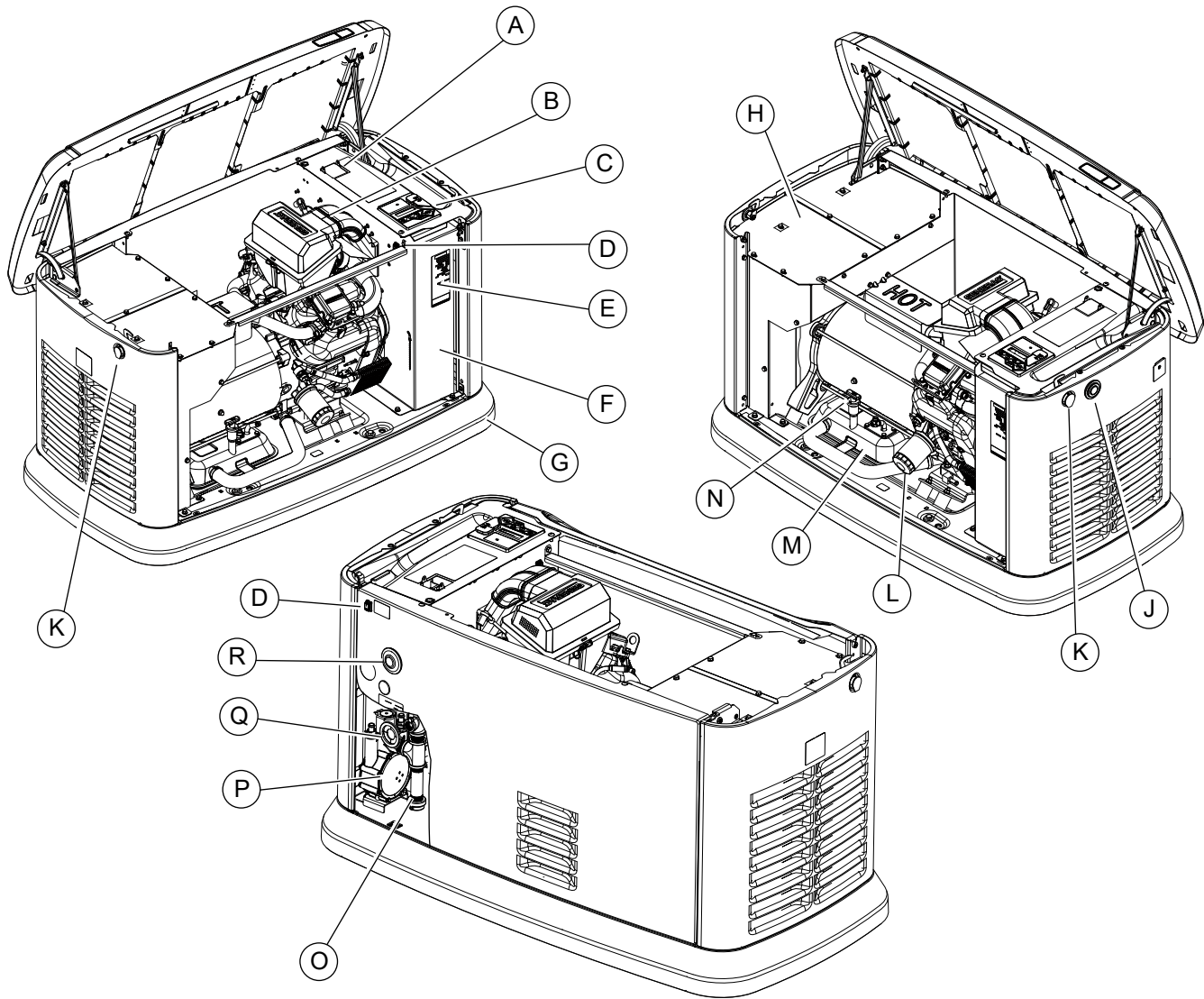

**Figure 2-1. Components and Control Locations**

A	Main line circuit breaker (generator disconnect)	F	Battery compartment (battery not supplied)	K	Lock with cover	O	Sediment trap
B	Airbox with air cleaner	G	Composite base	L	Oil filter	P	Fuel regulator
C	Control panel	H	Exhaust enclosure	M	Oil tank	Q	Fuel inlet
D	Generator emergency shutdown switch	J	Status LED indicators	N	Oil fill cap/oil dipstick	R	Wi-Fi module
E	Data decal location						

## Data Decals

Two decals on the generator provide information about the unit itself and required fuel inlet pressure for correct operation.

<div style="border: 1px solid black; padding: 10px;"> <p style="text-align: center;"><b>GENERAC</b></p> <p>MODEL: G0065510  SERIAL: 1000000XXX  ITEM NO: 0065510  PROD DATE: 20xx/xx/xx  VOLTS: 120/240 1 PHASE  LPV AMPS: 183.3/917 HZ: 60  NG AMPS: 162.5/81.3 RPM: 3600  INSULATION CLASS: F 10 PF  CONTROLLER P/N: OJ8371C  COUNTRY OF ORIGIN: USA  DUTY RTG: _____  XD 0.23 X'D 0.20  RATED AMBIENT TEMP: 40°C  FOR STANDBY SERVICE</p> <table border="0" style="width: 100%;"> <tr> <td style="width: 50%;">NEUTRAL FLOATING UNBALANCED LOAD CAPACITY: 25%</td> <td style="width: 50%;">MANUF. LOC. 1004</td> </tr> </table> <p style="text-align: center;">-----  RAINPROOF ENCLOSURE  -----</p> <div style="border: 1px solid black; padding: 5px; text-align: center;"> <small>Self ID No. 12204-01-01  Compliant with Clause (2)  of Section 4.14 of NFPA 37  LISTED BY: Southwest Research  Institute San Antonio, Texas</small> </div> <p>NOTE 1 ISO CHAR. MAX: _____  NOTE 2 ISO CHAR. MAX: _____  NOTE 3 ISO CHAR. MAX: _____  NOTE 4 ISO CHAR. MAX: _____  NOTE 5 ISO CHAR. MAX: _____  NOTE 6 ISO CHAR. MAX: _____  NOTE 7 ISO CHAR. MAX: _____</p> <p style="font-size: small;">GENERAC POWER SYSTEMS, INC  WALKESHA, WI USA 53189 0L2157</p> </div>	NEUTRAL FLOATING UNBALANCED LOAD CAPACITY: 25%	MANUF. LOC. 1004	<h3>Model Data Decal</h3> <p>Includes important information about the unit including:</p> <ul style="list-style-type: none"> <li>• model number</li> <li>• serial number</li> <li>• production date</li> <li>• voltage</li> <li>• frequency</li> <li>• amps</li> <li>• country of origin</li> <li>• rated ambient temperature.</li> </ul> <p>The model data decal also includes applicable certification symbols from independent testing agencies.</p>
NEUTRAL FLOATING UNBALANCED LOAD CAPACITY: 25%	MANUF. LOC. 1004		
<div style="border: 1px solid black; padding: 10px;"> <p style="text-align: center;"><b>FUEL INLET</b></p> <p>PRIMARY FUEL: _____ SERIAL: _____</p> <p><b>DIESEL</b>  MAX FLOW RATE: _____ BTU/HR</p> <p><b>NATURAL GAS</b>  MIN. INLET PRESSURE: _____ in W.C.  MAX INLET PRESSURE: _____ in W.C.  MAX FLOW RATE: _____ BTU/HR</p> <p><b>LP-VAPOR</b>  MIN. INLET PRESSURE: _____ in W.C.  MAX INLET PRESSURE: _____ in W.C.  MAX FLOW RATE: _____ BTU/HR</p> <p style="text-align: center;">_____ FLEX HOSE CONNECTION ONLY</p> </div>	<h3>Fuel Inlet Pressure</h3> <p>Displays unit serial number, along with minimum and maximum inlet pressures for natural gas (NG) and liquid propane (LP) supply. Space is provided for the installer to enter maximum flow rates based on installed pipe sizes and lengths.</p>		

## Specifications

### Generator

Model	15 kW EcoGen
Rated voltage	240
Rated maximum load current (amps) at rated voltage with LP*	62.5
Main line circuit breaker (generator disconnect)	70 Amp
Phase	1
Rated AC frequency	60 Hz
Battery requirement (field supplied)	12 volts, Group 26R-540CCA Minimum or Group 35AGM-650CCA Minimum (see <a href="#">Replacement Parts</a> )
Enclosure	Aluminum
Weight (lb/kg) (without battery)	460 (209)
Normal operating range	This unit is tested in accordance to UL 2200 standards with an operating temperature of -20 °F (-29 °C) to 122 °F (50 °C). When operated above 77 °F (25 °C) there may be a decrease in engine power. See <a href="#">Specifications</a> .
<p>These generators are rated in accordance with UL 2200, Safety Standard for Stationary Engine Generator Assemblies, and CSA-C22.2 No. 100-04 Standard for Motors and Generators.</p> <p>* Natural gas ratings will depend on specific fuel joules/BTU content. Typical derates are between 10-20% off the LP gas rating.</p>	

### Engine

Model	15 kW EcoGen
Engine type	G-Force™ 1000 Series
Number of cylinders	2
Displacement	999 cc
Valve clearance	0.002–0.004 in (0.05–0.1 mm)
Cylinder block	Aluminum with cast iron sleeve
Recommended spark plug	A0002081582
Spark plug gap	0.040 in (1.02 mm)
Starter	12 VDC
Oil capacity including filter	Approximately 3.75 qt (3.55 L)
Recommended oil filter	Part #070185E
Recommended air filter	Part #0J8478
<p>Engine power is subject to and limited by such factors as fuel BTU/joules, ambient temperature, and altitude. Engine power decreases approximately 3.5% for each 1000 ft (304.8 m) above sea level, and will also decrease about 1% for each 10 °F (6 °C) above 60 °F (15 °C) ambient temperature.</p>	

A detailed specification sheet for the particular generator is available from an IASD.

## Protection Systems

The generator may need to run for long periods of time with no operator present to monitor engine or generator conditions. The generator is equipped with protection systems to automatically shut down the unit to protect against potentially damaging conditions. Some of these systems include:

### Alarms:

- High Temperature
- Low Oil Pressure
- Overcrank
- Overspeed
- Overvoltage
- Undervoltage
- Overload
- Underspeed
- RPM Sensor Loss
- Controller Fault
- Wiring Error
- Stepper Overcurrent

### Warnings:

- Charger Warning
- Charger Missing AC
- Low Battery
- Battery Problem
- USB Warning
- Download Failure

The control panel contains a display alerting the operator when a fault condition occurs. The above list is not all-inclusive. See [Operation](#) for more information about alarms and control panel operation.

**NOTE:** A warning indicates a condition on the generator which should be addressed, but will not shut down the generator. An alarm shuts down the generator to protect the system from any damage. In the event of an alarm, an owner can clear the alarm and restart the generator prior to contacting an IASD. Contact an IASD if the intermittent issue occurs again.

## Emissions

The United States Environmental Protection Agency (US EPA) (and California Air Resources Board (CARB), for engines/equipment certified to California standards) requires this engine/equipment to comply with exhaust and evaporative emissions standards. Locate the emissions compliance decal on the engine to determine applicable standards. See the included emissions warranty for emissions warranty information. Follow the maintenance specifications in this manual to ensure the engine complies with applicable emissions standards for the duration of the product's life.

This generator is certified to operate on liquid propane vapor fuel or pipeline natural gas.

The Emission Control System code is EM (Engine Modification). The Emission Control System on this generator consists of the following:

System	Components
Air Induction	- Intake Manifold - Air Cleaner
Fuel Metering	- Carburetor and Mixer Assembly - Fuel Regulator
Ignition	- Spark Plug - Ignition Module
Exhaust	- Exhaust Manifold - Muffler

**NOTE:** Under U.S. EPA regulations, a mixer adjustment kit may be required when operating over 2,000 ft (609.6 m) above sea level. Contact an IASD for high altitude\* adjustment information.

\*High altitude is any elevation over 2,000 ft (609.6 m).

## Fuel Requirements



**⚠ DANGER**

Explosion and Fire. Fuel and vapors are extremely flammable and explosive. Add fuel in a well ventilated area. Keep fire and spark away. Failure to do so will result in death or serious injury.

(000105)

The engine has been fitted with a dual fuel carburetion system. The unit will run on NG or LP gas (vapor), but it has been factory set to run on NG. The fuel system will be configured for the available fuel source during installation.

Recommended fuels should have a BTU content of at least 1000 BTUs per ft<sup>3</sup> (37.26 megajoules per m<sup>3</sup>) for natural gas, or at least 2500 BTUs per ft<sup>3</sup> (93.15 megajoules per m<sup>3</sup>) for LP gas (vapor).

**NOTE:** If converting to LP gas from NG, a minimum LP tank size of 250 gal (946 L) is recommended. See the installation manual for complete procedures and details.

## Battery Requirements

12 volts, Group 26R-540CCA minimum or Group 35AGM-650CCA minimum (not included with unit.) See [Maintenance](#) for correct battery maintenance procedures.

## Engine Oil Requirements

See [Engine Oil Requirements](#) in the Maintenance section for correct oil viscosity.

## Activating the Generator

The generator should be activated upon initial start-up. See installation manual for complete instructions.

## Wi-Fi Module

The generator is equipped with a Wi-Fi module. See Wi-Fi module owner's manual for further instructions.

## Replacement Parts

Description	15 kW EcoGen
26R Battery	0H3421S
Spark plug	A0002081582
Oil filter	070185E
Air filter	0J8478
Control panel fuse	0D7178T
Rotor brushes	0J8415

## Accessories

**NOTE:** Performance enhancing accessories are available for air-cooled generators. Contact an IASD or visit [www.generac.com](http://www.generac.com) for additional information on replacement parts, accessories, and extended warranties. See also <http://www.ordertree.com/generac/air-cooled-homestandby-generators/>.

Accessory	Description
Cold Weather Accessories*— <ul style="list-style-type: none"> <li>• Battery Pad Warmer</li> <li>• Oil Warmer</li> <li>• Breather Warmer</li> </ul> * each sold separately.	<ul style="list-style-type: none"> <li>• Recommended in areas where temperatures fall below 0 °F (-18 °C). (<i>Not necessary for use with AGM-style batteries</i>)</li> <li>• Recommended in areas where temperatures fall below 0 °F (-18 °C).</li> <li>• Recommended in areas where heavy icing occurs.</li> </ul> <p><i>NOTE: Battery heaters and oil heaters require N1 and N2 connections to 240V utility. Breather heater requires T1 connection to 120V.</i></p>
Scheduled Maintenance Kit	Provides all items necessary to perform complete routine maintenance on a generator, along with oil recommendations (oil not included).
Touch-Up Paint Kit	Very important to maintain the look and integrity of the generator enclosure. This kit includes touch-up paint and instructions.
Wireless Local Monitor	The Wireless Local Monitor is completely wireless and battery powered, and provides owners with instant generator status updates without ever leaving the house. Status lights (red, yellow, and green) alert owners when the generator needs attention. Magnetic backing permits refrigerator mounting and gives a 600 ft (183 m) line of sight communication.
LTE LP Fuel Level Monitor	The LTE enabled LP fuel level monitor provides constant monitoring of the connected LP fuel tank. Monitoring the LP tank level is an important step in making sure your generator is ready to run during an unexpected power failure. Status alerts are available through the Mobile Link <sup>®</sup> application informing you when your LP tank needs a refill.
Base Plug Kit	Base plugs snap into the lifting holes on the base of air-cooled home standby generators. This offers a sleek, contoured appearance, as well as offers protection from rodents and insects by covering the lifting holes located in the base. Base plug kit contains four base plugs, sufficient for use on a single air-cooled home standby generator.
High Altitude Kit	A high altitude kit may be required when operating over 2,000 ft (610 m) above sea level per U.S. EPA regulations. Operating the engine with the incorrect engine configuration at a given altitude may increase emissions and decrease fuel efficiency and performance.

## Section 3: Operation

### Site Prep Verification

#### **⚠ DANGER**

Automatic start-up. Disconnect utility power and render unit inoperable before working on unit. Failure to do so will result in death or serious injury.

(000191)

Generator must be installed to allow unimpeded airflow into and out of the generator.

Mechanical and gravity outdoor air intake openings for air distribution and supply systems must be located not less than 10 ft (3.05 m) horizontally from the generator enclosure. See Section 401.4 in the ICC Mechanical Code for additional information.

Verify all shrubs or tall grasses within 3 ft (0.91 m) of the intake and discharge louvers on the sides of the enclosure have been removed. Install generator on high ground where water levels will not rise and endanger it. This unit should not operate in or be subjected to standing water. Verify all potential water sources such as water sprinklers, roof run-off, rain gutter downspouts, and sump pump discharges are directed away from unit.

### Generator Enclosure

Enclosure lid is locked prior to shipment. A set of keys is attached to cardboard on top of generator. An additional set of keys is attached to pallet bracket on the front intake end of generator.

**NOTE:** Keys provided with this unit are intended for service personnel use only.

#### Opening the Lid

1. Use keys to open generator lid.
2. See [Figure 3-1](#). Two locks (A) secure lid; one on each side. Open protective rubber cap to access keyhole.

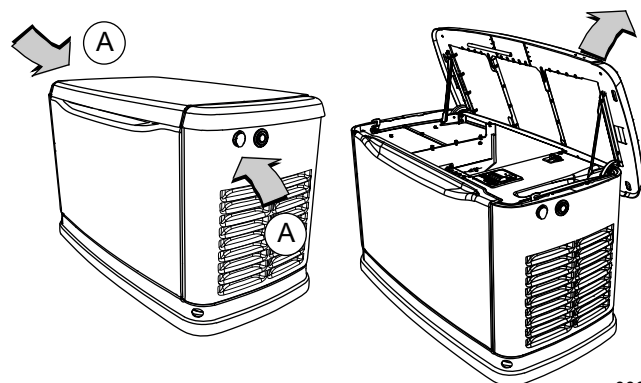

009209

**Figure 3-1. Opening the Lid**

3. Press down on lid above side lock, and unlock latch to correctly open lid.
4. Repeat for other side. Lid may appear stuck if pressure is not applied from the top.

**NOTE:** Always verify side locks are unlocked before attempting to lift lid.

#### Front Access Panel Removal

See [Figure 3-2](#). Remove front access panel (A) by lifting straight up and out once lid is open.

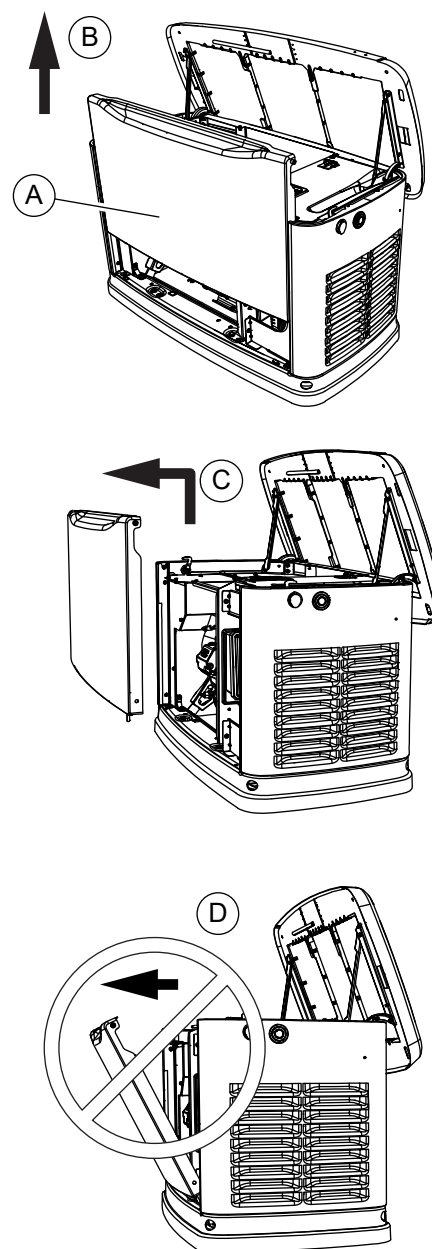

009210

**Figure 3-2. Remove Front Access Panel**

**NOTE:** Always lift front access panel straight up before pulling away from enclosure (B and C). Do not pull panel away from the enclosure before lifting up (D).

### Intake Side Panel Removal

See **Figure 3-3**. Intake side panel (A) must be removed to access battery compartment, fuel regulator, and sediment trap.

1. Raise lid and remove front panel.
2. Use a hex key to remove two mounting screws (B) and L-bracket screw (C).
3. Lift intake panel up and away from generator.

**NOTE:** Always lift intake side panel straight up before pulling away from enclosure. Do not pull panel away from enclosure before lifting up (D).

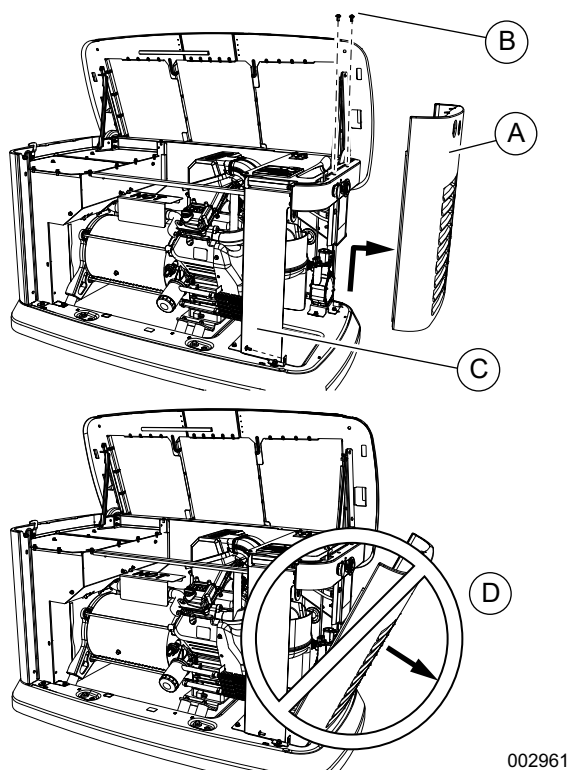
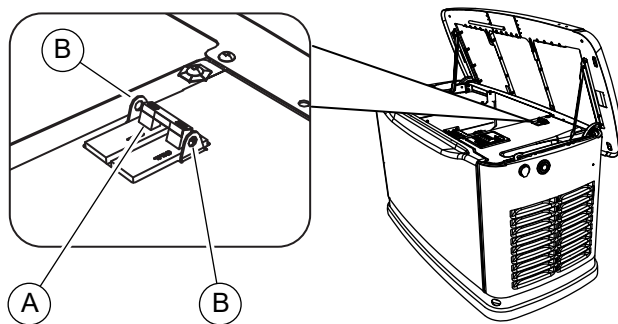

**Figure 3-3. Intake Side Panel Removal**

### Main Line Circuit Breaker (Generator Disconnect)

See **Figure 3-4**. This is a 2-pole main line circuit breaker (MLCB) (generator disconnect) (A) rated according to relevant specifications.

The generator MLCB (generator disconnect) can be locked in OFF (OPEN) for security. Use an appropriately-sized padlock (not included) with a shackle long enough to pass through both lock tabs (B).



001810

**Figure 3-4. Generator MLCB (Generator Disconnect)**

**NOTE:** DO NOT lock out the generator MLCB (generator disconnect) during normal generator operation. Doing so will compromise automatic standby functionality.

### LED Indicator Lights

See **Figure 3-5**. Three LEDs are visible behind a translucent lens on the generator side panel. These LEDs indicate generator operating status.

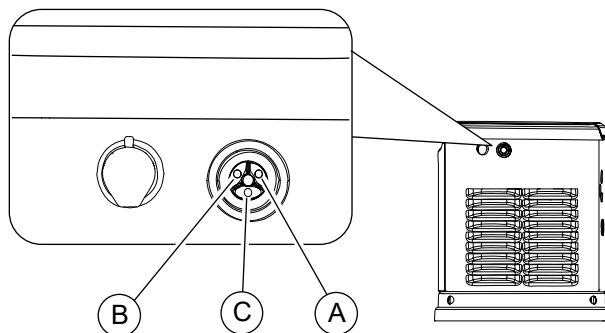

001791

**Figure 3-5. LED Indicator Lights**

- Green LED “Ready” light (A) is illuminated when utility is present and control panel is in AUTO. LED flashes when automatic transfer switch converts to generator power during a utility power outage.
- Red LED “Alarm” light (B) is illuminated when generator is OFF or a fault is detected. Contact an IASD.
- Yellow LED “Non-Critical Alert” light (C) is illuminated when maintenance is required.

**NOTE:** Yellow LED may be illuminated at the same time as either the red or green LED.

## Generator Emergency Shutdown Switch



Equipment Damage. The emergency shutdown switch is not to be used to power down the unit under normal operating circumstances. Doing so will result in equipment damage. (000399a)

All generators are equipped with an external means of shutting down the generator which complies with the latest NEC code requirement. The primary generator shutdown sequence is described in [Shutting Generator Down While Under Load or During a Utility Outage](#).

See [Figure 3-6](#). There is a generator emergency shutdown switch (A) on the exterior of the generator back panel. This emergency shutdown switch shuts down generator and disables restarts.

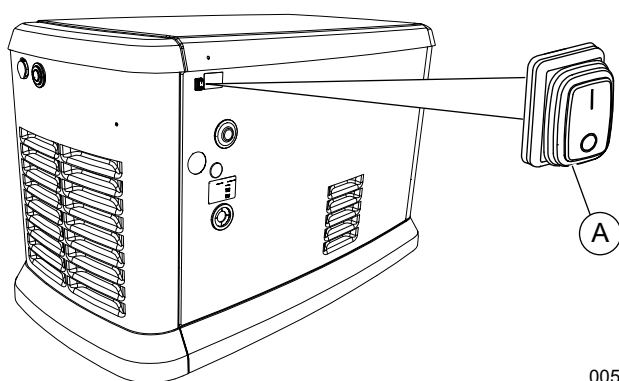

005492

**Figure 3-6. External Emergency Shutdown Switch**

**NOTE:** Whenever possible, perform the primary shutdown procedure before disabling the generator with the emergency shutdown switch.

See [Figure 3-7](#). A second emergency shutdown switch (B) is located inside the generator.

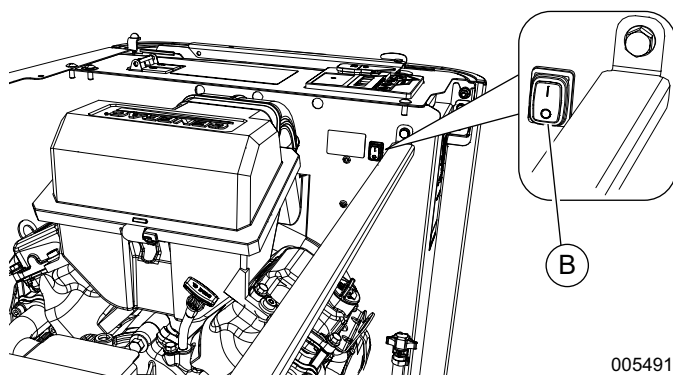

005491

**Figure 3-7. Internal Emergency Shutdown Switch**

**NOTE:** Generator will not start if either switch is OPEN (O). The controller displays a “Shutdown Switch” alarm, and the red LED “Alarm” light illuminates. To clear this

condition, set switch or switches to CLOSED (I). Clear alarm by pressing OFF button, and then ENTER. Generator can then be placed back in AUTO or MANUAL.

## Control Panel Interface

See [Figure 3-8](#). The control panel interface (A) is located under the enclosure lid. Verify both the left and right side locks are unlocked before attempting to lift the lid of the enclosure. Open the lid as directed in [Opening the Lid](#).

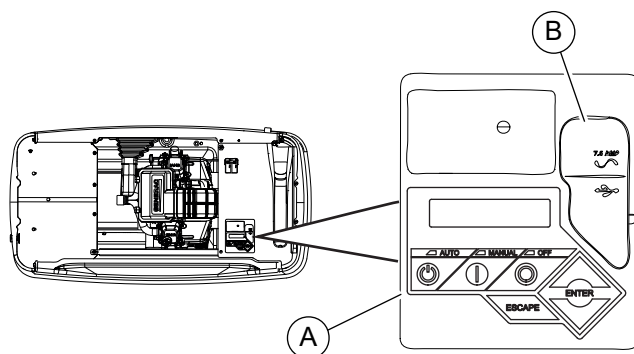

001798

**Figure 3-8. Generator Control Panel**

The 7.5A fuse is located beneath the rubber cover (B) to the right of the control panel.

Verify both left and right side locks are securely out of the way before closing the unit.

All appropriate panels must be in place during any operation of the generator. This includes operation by a servicing technician while conducting troubleshooting procedures.

## Using the AUTO/OFF/MANUAL Buttons

Button	Description of Operation
AUTO	Activates fully automatic system operation. Allows unit to start automatically through two-wire start when off-grid mode is enabled, or when utility is lost with off-grid mode disabled. Green LED flashes when automatic transfer switch converts to generator power during a utility power outage.
OFF	Shuts down engine and prevents automatic operation of unit.
MANUAL	Cranks and starts generator. Transfer to standby power will not occur unless there is a utility failure. Blue LED flashes when automatic transfer switch converts to generator power during a utility power outage.

**NOTE:** Damage caused by mis-wiring of interconnect wires is not warrantable.

## Operating Modes

Mode	Description
MANUAL	<ul style="list-style-type: none"> <li>• Will not transfer to generator if utility is present.</li> <li>• Will transfer to generator if utility drops (below 65% of nominal for five consecutive seconds; dealer programmable) after warm-up.</li> <li>• Will transfer back when utility returns for 15 consecutive seconds (dealer programmable). The engine will continue to run until removed from MANUAL mode.</li> </ul>
AUTO	<ul style="list-style-type: none"> <li>• Will start and run if utility drops for five consecutive seconds (dealer programmable).</li> <li>• Will start an engine warm-up timer (duration varies when <b>Cold Smart Start</b> is enabled).                             <ul style="list-style-type: none"> <li>–Will not transfer if utility subsequently returns.</li> <li>–Will transfer to generator if utility is not present.</li> </ul> </li> <li>• Will transfer to utility once utility returns (above 80% of nominal) for 15 consecutive seconds (dealer programmable).</li> <li>• Will not transfer to utility unless utility returns. Generator will shut down if OFF button is pressed or a shutdown alarm is present.</li> <li>• Once utility power is returned, generator will shut down after one minute cool-down time.</li> </ul>

## Interface Menu Displays

### LCD Panel

Feature	Description
HOME page	<p>Default page displayed if no buttons are pressed for 60 seconds. Normally shows current status message, and current date and time. Highest priority active alarm/warning is automatically posted on this page, as well as flashing the backlight when such a condition is detected. In the case of multiple alarms/warnings, only the first message is displayed. Press OFF button and then ENTER button to clear an alarm or warning.</p> <p>When “Hours of Protection” is displayed, this represents total time the generator has been monitoring utility supply and ready to provide backup power if needed.</p>
Display Backlight	<p>Normally off. Backlight will automatically illuminate and remain on for 30 seconds if the operator presses any button.</p>
MAIN MENU page	<p>Allows operator to navigate to all other pages or sub-menus by using the arrow keys and the ENTER button. Page can be accessed at any time with several presses of the dedicated ESCAPE button. Each press of the ESCAPE button takes the operator to the previous menu until the MAIN MENU displays. This page contains information for History; Status; Edit; and Debug.</p>

### Menu System Navigation

Press ESCAPE button from any page to access the MENU. If needed, press ESCAPE button several times to reach the MENU page. Navigate to desired menu by using the ↑/↓ buttons. Press ENTER button when desired menu is displayed and flashing.

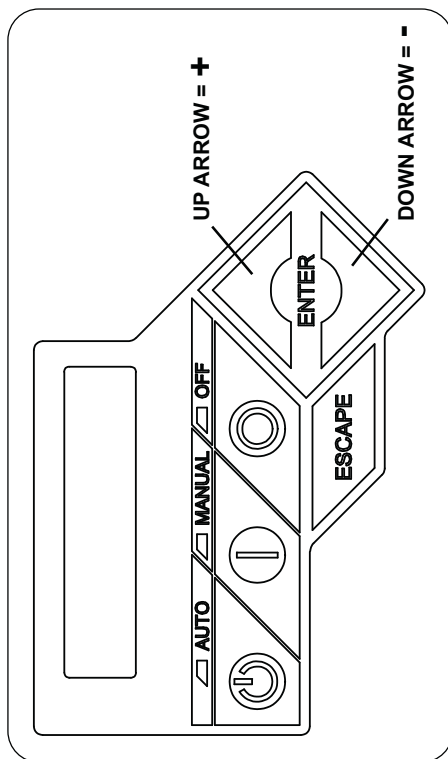

### EVOLUTION 2.0 / SYNC 3.0 HSB MENU MAP

Note: Menu functions and features may vary depending on unit model and firmware revision.

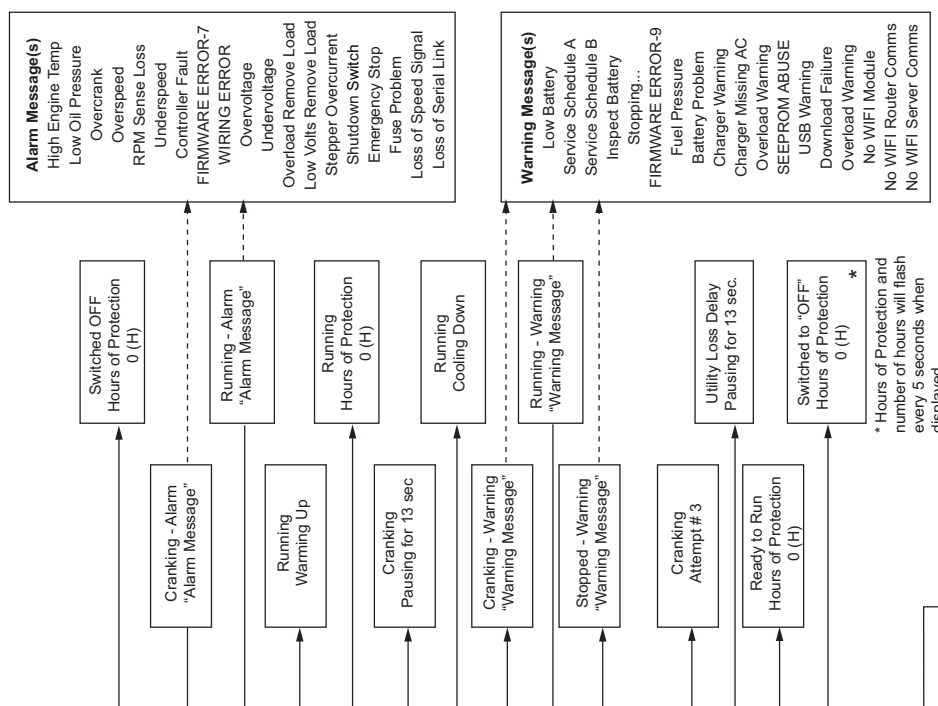

Figure 3-9. Navigation Menu



## Setting the Exercise Timer

This off-grid generator is not configurable to run in exercise mode. If exercise is desired, MANUAL mode may be used if the connected loads are prepared to accept the electrical output while running, or the generator MLCB (generator disconnect) is OFF (CLOSED). If using MANUAL mode, generator will operate at the rated 3,600 rpm until the OFF button is pressed.

**NOTE:** If Wi-Fi is enabled, Mobile Link® application should not be used to initiate exercise mode if the user does not wish the generator to exercise.

**IMPORTANT NOTE:** Do not place generator in exercise mode if the generator MLCB (generator disconnect) is ON (CLOSED). An unexpected power surge may damage connected equipment such as an inverter.

## Battery Charger

**IMPORTANT NOTE:** Contact an IASD if the controller screen displays “CHARGER MISSING AC.”

**NOTE:** The battery charger is integrated into the control module in all models.

The battery charger operates as a smart charger which verifies:

- output is continually optimized to promote maximum battery life.
- charging levels are safe.

If the internal battery charger is not connected to utility power, the controller will drain the 12VDC battery if not properly maintained. Total power usage of controller and Wi-Fi module while the generator is not running is 2.5 W.

**NOTE:** A warning is displayed on the LCD when the battery needs service.

**NOTE:** Do not use external battery chargers with Off-Grid mode disabled and unit equipped with a transfer switch.

**NOTE:** With Off-Grid mode enabled and unit equipped with a two-wire start, use an external battery charger to maintain the battery if the T1 connection is not connected to utility.

## Two-Wire Start Signal and Off-Grid Mode Enabled

See **Table 3-1**. The engine cranks if the generator is set to AUTO and the two-wire start is ON (CLOSED). If the generator MLCB (generator disconnect) is set to ON (CLOSED), power will be immediately provided to connected electrical loads. The engine will shut down once the two-wire start is OFF (OPEN).

**NOTE:** By default, there is no generator cooldown while operating with Off-Grid mode ENABLED. To perform a cooldown without electrical loads connected, set the generator MLCB (generator disconnect) to OFF (OPEN) and run the generator in MANUAL mode. Press the OFF button to end the cooldown.

**NOTE:** Verify cooldown setting is set to the desired condition prior to Off-Grid mode operation.

<b>Table 3-1. Off-Grid Mode Enabled and Equipped with Two-Wire Start</b>	
<b>MANUAL</b>	<ul style="list-style-type: none"> <li>• Will provide power to connected loads if generator MLCB (generator disconnect) is ON (CLOSED).</li> <li>• Will not provide power to connected loads if generator MLCB (generator disconnect) is OFF (OPEN).</li> </ul>
<b>AUTO</b>	<ul style="list-style-type: none"> <li>• Will start immediately when two-wire start wires are ON (CLOSED).</li> <li>• Will provide power to connected loads if generator MLCB (generator disconnect) is ON (CLOSED).</li> <li>• Will not provide power to connected loads if generator MLCB (generator disconnect) is OFF (OPEN).</li> <li>• Will shut down immediately when two-wire start wires are OFF (OPEN).</li> </ul>

## Manual Transfer Operation (if equipped)



**⚠ DANGER**

Electrocution. Do not manually transfer under load. Disconnect transfer switch from all power sources prior to manual transfer. Failure to do so will result in death or serious injury, and equipment damage.

(000132)

Prior to automatic operation, manually exercise the transfer switch to verify there is no interference with correct operation of the mechanism. Manual operation of the transfer switch is required if electronic operation should fail.

### Transfer to Generator Power Source

Proceed as follows to transfer to generator power source:

1. Verify generator is OFF.
2. Set generator MLCB (generator disconnect) to OFF (OPEN).
3. Turn OFF utility power supply to the transfer switch using the means provided (such as a utility MLCB).
4. See [Figure 3-11](#). Use the manual transfer handle (A) inside the transfer switch to set main contacts to STANDBY (loads connected to the standby power source).

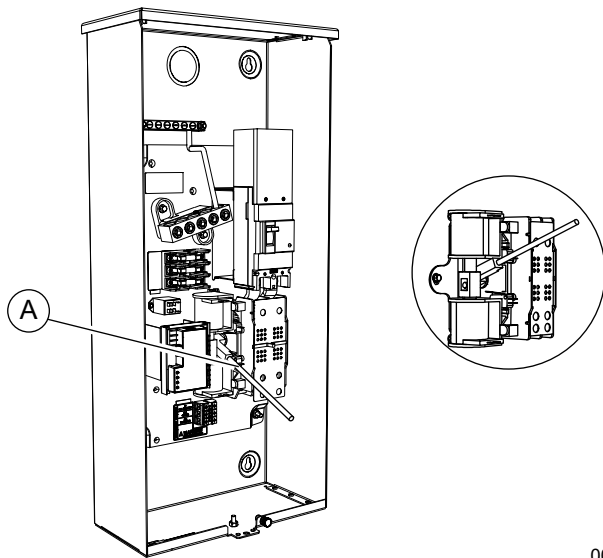

002565

**Figure 3-11. Typical Manual Transfer Switch Operation**

5. Press MANUAL button on generator to crank and start engine.
6. Allow engine to stabilize and warm up for a few minutes.
7. Set generator MLCB (generator disconnect) to ON (CLOSED). The standby power source now powers the loads.

### Transfer to Utility Power Source

Shut down generator and transfer to utility source after utility power has been restored. Proceed as follows to manually transfer to utility power and shut down the generator:

1. Set generator MLCB (generator disconnect) to OFF (OPEN).
2. Run engine for one minute at no-load to stabilize the internal temperature.
3. Press OFF mode button on the control panel. The engine will shut down.
4. Verify utility power supply to the transfer switch is turned OFF.
5. Set main contacts to UTILITY (loads connected to the utility power source) using the manual transfer handle inside the transfer switch.
6. Turn on utility power supply to transfer switch using the means provided (such as a utility MLCB).
7. Press AUTO button on the control panel.
8. Set generator MLCB (generator disconnect) to ON (CLOSED).
9. Close and lock the lid.

### Automatic Transfer Operation

Proceed as follows to select automatic operation:

1. Verify transfer switch main contacts are set to UTILITY (loads connected to the utility power source).
2. Verify normal utility power source voltage is available to loads connected to the transfer switch.
3. Press AUTO button on the generator control panel.
4. Set generator MLCB (generator disconnect) to ON (CLOSED).

The generator will start automatically when utility source voltage drops below a preset level. Loads are transferred to standby power source after the unit starts.

### Automatic Sequence of Operation

#### Utility Failure (if equipped with Transfer Switch and Off-Grid Mode Disabled)

If generator is set to AUTO and equipped with a transfer switch, a five second (dealer-programmable) line interrupt delay timer begins when utility fails (below 65% of nominal). Engine cranks and starts if utility power is still unavailable when timer expires. An engine warm-up timer will be initiated once the engine is started. Timer duration varies depending on whether or not **Cold Smart Start** is enabled. The controller will transfer load to the generator when the warm-up time expires. If utility power is restored (above 80% nominal) at any time from the initiation of the engine start until generator is ready to accept load (warm-up time has not elapsed), the control-

ler completes the start cycle and runs the generator through its normal cool down cycle. However, load will remain on the utility source.

### Cranking

The system will control the cyclic cranking as follows:

- Five cranking cycles as follows: 16 seconds cranking, 7 seconds resting, 16 seconds cranking, 7 seconds resting, followed by three additional cycles of 7 seconds cranking followed by 7 seconds resting.

**NOTE:** An alarm will be triggered if the generator does not start after these five attempts.

### Cold Smart Start

The generator will monitor ambient temperature when Cold Smart Start is enabled. The warm-up delay will be adjusted based on prevailing conditions. Cold Smart Start is factory-enabled, but can be disabled in the EDIT menu.

See [Table 3-2](#). If the ambient temperature is below a fixed temperature upon startup in AUTO, generator will warm up for 30 seconds. This allows the engine to warm before a load is applied. The generator will startup with the normal warm-up delay of five seconds if the ambient temperature is at or above the fixed temperature.

**Table 3-2. Cold Smart Start Set Points**

Table 3-2. Cold Smart Start Set Points	
<b>Generator Size</b>	<b>15 kW EcoGen</b>
<b>Fixed Temperature</b>	50 °F (10 °C)

A check for correct output voltage buildup will be performed when the generator engine is started.

If some condition impedes normal voltage creation, such as frost crystals or dust/dirt preventing a good electrical connection, the start sequence will be interrupted so a cleaning cycle of the internal electrical connections can be attempted.

The cleaning cycle is an extended warming up period which lasts for several minutes while the normal generator voltage output is determined to be low. During this cycle, the generator controller will display “Warming Up” on the display screen.

The generator controller display will show “Under Voltage” if the cleaning cycle fails to clear the obstruction. After several minutes, the alarm message can be cleared, and the generator restarted.

If the problem persists, make no further attempts to start. Contact an IASD.

**NOTE:** Cold Smart Start warmup is only available when Off-Grid mode is DISABLED.

### Load Transfer

The transfer of load when the generator is running is dependent upon the operating mode.

## Shutting Generator Down While Under Load or During a Utility Outage



Automatic start-up. Disconnect utility power and render unit inoperable before working on unit.

Failure to do so will result in death or serious injury.

(000191)

**IMPORTANT NOTE:** To avoid equipment damage, follow these steps, in order, during utility outages. Shutdowns may be required during utility outages to perform routine maintenance or to conserve fuel.

#### To turn generator OFF:

1. Set utility MLCB to OFF (OPEN).
2. Set generator MLCB (generator disconnect) to OFF (OPEN).
3. Allow generator to run for cool-down for approximately one minute.
4. Set generator to OFF at the controller.
5. Remove 7.5A fuse from controller.

#### To turn generator back ON:

1. Install 7.5A fuse in controller.
2. Verify generator MLCB (generator disconnect) is OFF (OPEN).
3. Set generator to AUTO mode at the controller.
4. Generator will start and run. Allow generator to run and warm up for a few minutes.
5. Set generator MLCB (generator disconnect) to ON (CLOSED).
6. Set utility MLCB to ON (CLOSED).

The system now operates in automatic mode.

**This page intentionally left blank.**

## Section 4: Maintenance

### Maintenance

Regular maintenance will improve performance and extend engine/equipment life. Generac Power Systems, Inc. recommends that all maintenance work be performed by an Independent Authorized Service Dealer (IASD). Regular maintenance, replacement, or repair of the emissions control devices and systems may be performed by any repair shop or person of the owner's choosing. To obtain emissions control warranty service free of charge, the work must be performed by an IASD. See the emissions warranty.

### Preparing for Maintenance

---

#### DANGER

Automatic start-up. Disconnect utility power and render unit inoperable before working on unit. Failure to do so will result in death or serious injury.

(000191)

---

#### WARNING

Equipment damage. Only qualified service personnel may install, operate, and maintain this equipment. Failure to follow proper installation requirements could result in death, serious injury, and equipment or property damage.

(000182a)

---

Proceed as follows to prepare for maintenance:

1. Set utility MLCB to OFF (OPEN).
2. Lift lid and set generator MLCB (generator disconnect) on generator to OFF (OPEN).
3. Allow generator to run and cool down for one minute with no load (if running during a utility outage).
4. Press OFF button on controller.
5. Remove 7.5A fuse from control panel.
6. Remove front panel and intake side panel.

### Performing Scheduled Maintenance

It is important to perform maintenance as specified in the [Service Schedule](#) for correct generator operation. Engine oil and oil filter must be changed, and valve clearance adjusted after the first 25 hours of operation.

Emissions-critical maintenance must be performed as scheduled in order for the emissions warranty to be valid. Emissions-critical maintenance consists of servicing the air filter and spark plugs in accordance with the [Service Schedule](#).

The controller will prompt for Schedule A or Schedule B maintenance to be performed. Schedule A maintenance consists of the oil, oil filter, and battery check. Schedule B maintenance includes the oil, oil filter, battery check, air cleaner, spark plugs, and valve clearance.

Since most maintenance alerts occur at the same time (most have two year intervals), only one will appear on the control panel display at a time. Once the first alert is cleared, the next active alert will be displayed.

## Service Schedule

Service	Weekly	Every Three Months	Every Year	Schedule A Every Two Years or 500 Hours	Schedule B Every Four Years or 1000 Hours
Inspect enclosure louvers for dirt and debris*	•				
Inspect lines and connections for fuel or leaks		•			
Inspect engine oil level		•			
Inspect for water intrusion **			•		
Perform fuel system leak test			•		
Check battery condition, electrolyte level, and state of charge			•	•	•
Replace engine oil and oil filter †				•	•
Replace engine air filter				•	•
Clean; inspect spark plug gap; replace if necessary					•
Inspect/adjust valve clearance ‡				•	•
Replace rotor brushes					•
Inspect/clean sediment trap	Consult local codes and guidelines.				

Contact the nearest IASD for assistance if necessary.

\* Remove any shrubs or tall grasses which have grown within 3 ft (0.91 m) of intake and discharge louvers on enclosure sides. Clean any debris (dirt, grass clippings, etc.) which may have accumulated inside the enclosure.

\*\* Verify all sources of potential water intrusion such as water sprinklers, roof run-off, rain gutter downspouts, and sump pump discharges are directed away from generator enclosure.

† Change engine oil and filter after the first 25 hours of operation. In cold weather conditions (ambient below 40 °F [4.4 °C]), or if unit is operated continuously in hot weather conditions (ambient above 85 °F [29.4 °C]), change engine oil and filter every year or 100 hours of operation.

‡ Check/adjust valve clearance after the first 25 hours of operation.

**NOTE:** Contact an IASD or visit [www.generac.com](http://www.generac.com) for additional information on replacement parts.

## Maintenance Log

### Battery Inspection and Charge Check

Dates Performed:

### Oil, Oil Filter, Air Filter, and Spark Plug Replacement

Dates Performed:

### Valve Adjustment

Dates Performed:

## Checking Engine Oil Level



### WARNING

Risk of burns. Allow engine to cool before draining oil or coolant. Failure to do so could result in death or serious injury.

(000139)

### WARNING

Skin irritation. Avoid prolonged or repeated contact with used motor oil. Used motor oil has been shown to cause skin cancer in laboratory animals. Thoroughly wash exposed areas with soap and water.

(000210)

### CAUTION

Engine damage. Verify proper type and quantity of engine oil prior to starting engine. Failure to do so could result in engine damage.

(000135)

**IMPORTANT NOTE:** Check oil level daily when power outages necessitate running the generator for extended periods.

Proceed as follows to check engine oil level:

1. Set utility MLCB to OFF (OPEN).
2. Set generator MLCB (generator disconnect) to OFF (OPEN).
3. Run generator for a cool-down period of approximately one minute.
4. Press OFF button to turn generator off. Wait five minutes.
5. See [Figure 4-1](#). Remove oil dipstick (A) and wipe it dry with a clean cloth.

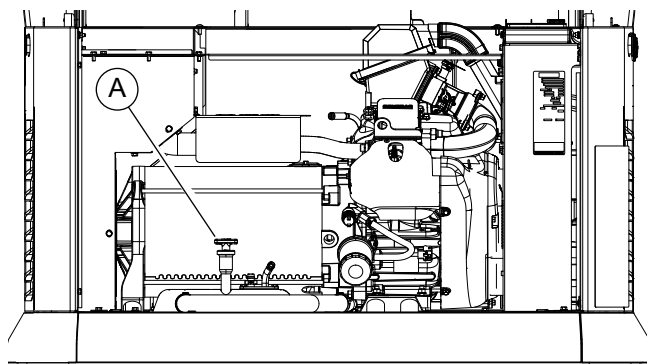

008723

**Figure 4-1. Dipstick Location**

6. Completely insert oil dipstick into oil dipstick tube and remove it.
7. Observe oil level. The level should be at the "FULL" mark on oil dipstick.

8. If necessary, remove oil fill cap and add oil to engine (with oil dipstick removed) until level reaches "FULL" mark. Insert oil dipstick and install fill cap.

To restart the generator:

1. Press AUTO button on control panel.
2. Allow generator to start and warm up for a few minutes.
3. Set generator MLCB (generator disconnect) to ON (CLOSED).

The system is now operating in AUTO. The utility MLCB can be turned ON (CLOSED).

## Engine Oil Requirements

The engine oil should be serviced in accordance with the recommendations of this manual to maintain the product warranty. Generac Maintenance Kits are available consisting of engine oil, oil filter, air filter, spark plugs, a shop towel, and a funnel are available from an IASD.

All Generac oil kits meet minimum American Petroleum Institute (API) Service Class SJ, SL, or better. Do not use special additives.

After the 25 hour break-in period (and at every interval there-after), it is recommended to use Generac's proprietary 5W-20 gaseous engine oil (GEO) for continuous use. It is specifically formulated for use in gaseous powered Generac generators.

## Changing Oil and Oil Filter

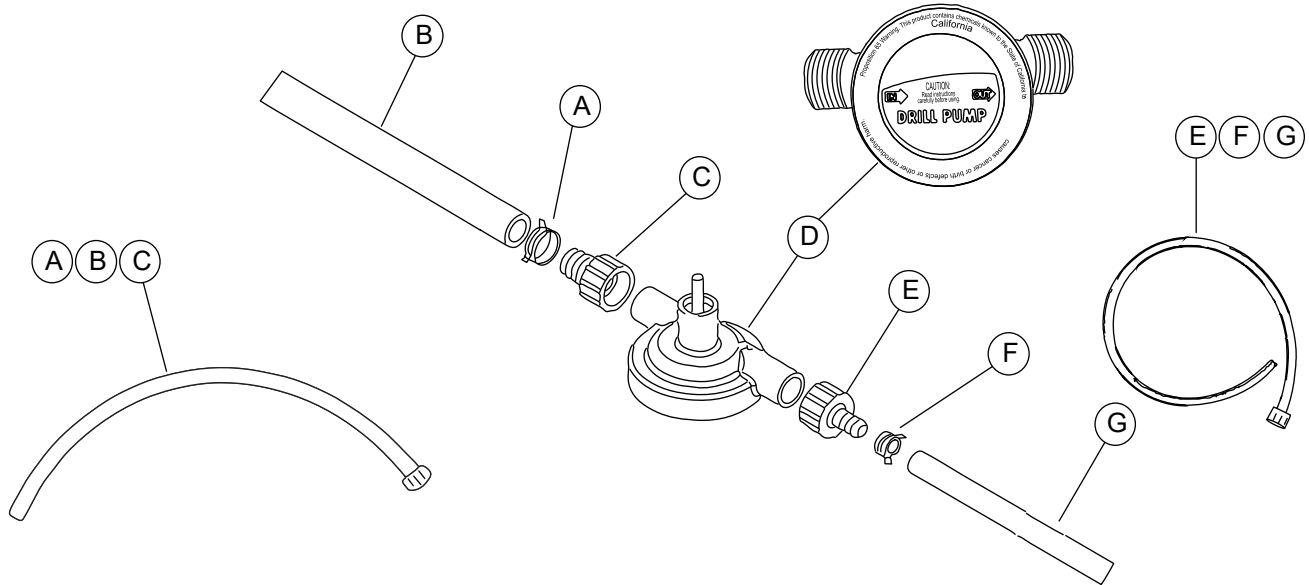

001385

**Figure 4-2. Exploded View – Oil System Drain Pump Kit**

An Oil System Drain Pump Kit (P/N 0K3717) has been shipped with this unit. See instructions included with the kit for assembly and use of the oil system drain pump. If the oil system drain pump is lost, or unavailable, use a suitable suction pump to perform the following oil change procedure.

### Assembling Oil System Drain Pump

Proceed as follows to assemble oil system drain pump:

1. See **Figure 4-3**. Install  $\frac{1}{4}$  in hose assembly onto inlet side of drill pump. Twist fitting clockwise until it is snug. Do not over-tighten.

### Oil System Drain Pump Kit Parts List

(Kit Part No. 0K3717)

A	$\frac{3}{4}$ in Spring clamp**
B	$\frac{1}{2}$ in Rubber hose**
C	$\frac{1}{2}$ in Barb hose fitting with $\frac{3}{4}$ in hose thread**
D	Drill pump
E	$\frac{1}{4}$ in Barb hose fitting with $\frac{3}{4}$ in hose thread*
F	$\frac{1}{2}$ in Spring clamp*
G	$\frac{1}{4}$ in Rubber hose*
* Parts 1, 2, and 6 come assembled from the supplier.	
** Parts 3, 4, and 7 come assembled from the supplier.	

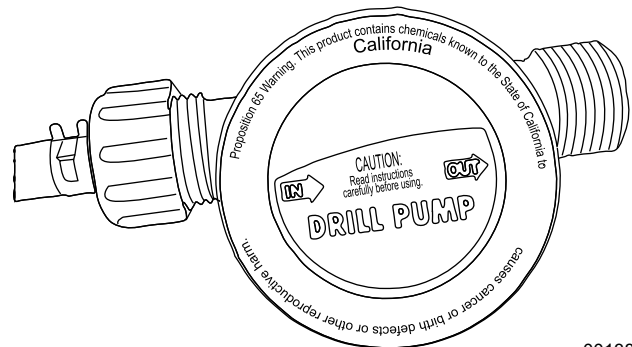

001386

**Figure 4-3. Pump Assembly Step 1**

2. See **Figure 4-4**. Install  $\frac{1}{2}$  in hose assembly onto outlet side of drill pump. Twist fitting clockwise until it is snug. Do not over-tighten.

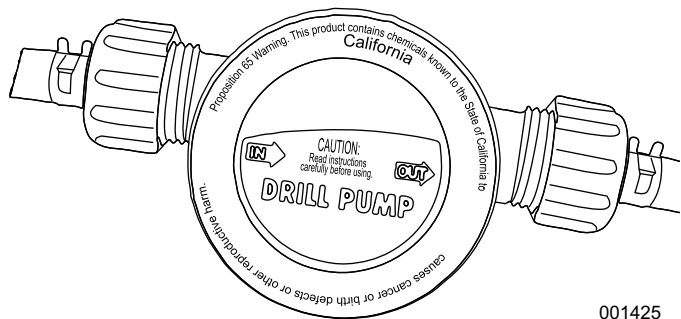

001425

**Figure 4-4. Pump Assembly Step 2**

## EcoGen Oil Change Procedure

### **WARNING**

Skin irritation. Avoid prolonged or repeated contact with used motor oil. Used motor oil has been shown to cause skin cancer in laboratory animals. Thoroughly wash exposed areas with soap and water.

(000210)

Proceed as follows to change the oil:

1. Set generator MLCB (generator disconnect) to OFF (OPEN).
2. Press MANUAL button to operate the unit.
3. Allow engine to warm up to operating temperature, by running unit for approximately 20 minutes
4. Press OFF button to shut down engine.
5. Allow oil to settle for 10 minutes.

**NOTE:** Allowing engine to run at operating temperature increases engine oil viscosity so it can be easily drawn out of the system. Allowing oil to settle ensures oil has thoroughly drained to the tank and equipment is cool enough to handle during the procedure. Always follow all safety precautions when working with this equipment.

6. See **Figure 4-5**. Remove oil filter (A) by turning it counterclockwise. A towel or small container may be used to catch any residual oil when removing filter.

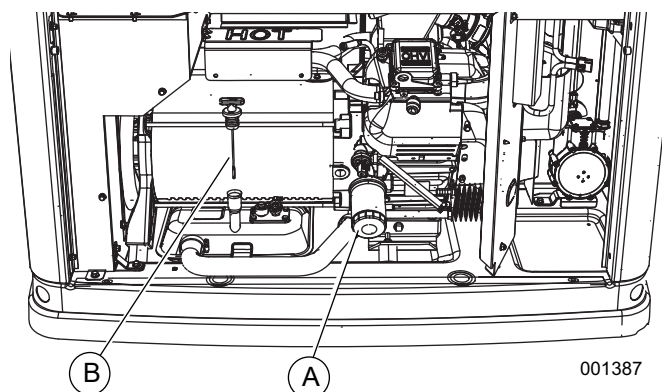

001387

**Figure 4-5. Oil Filter and Dipstick**

7. Remove oil dipstick (B) from oil tank.
8. Set a drill to spin in the clockwise direction.
9. See **Figure 4-6**. Attach drill to drill pump drive shaft.

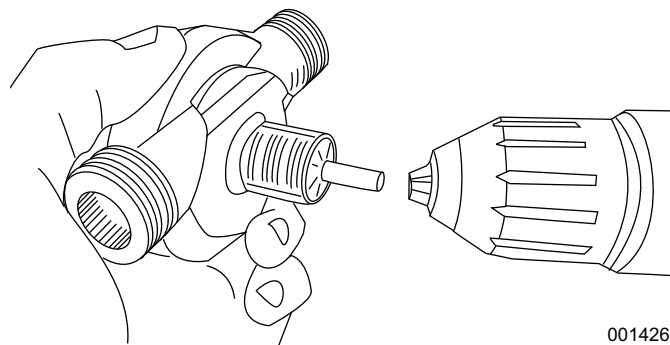

001426

**Figure 4-6. Attach Drill Pump**

10. See **Figure 4-7**. Insert  $\frac{1}{4}$  in hose free end into unit oil tank.

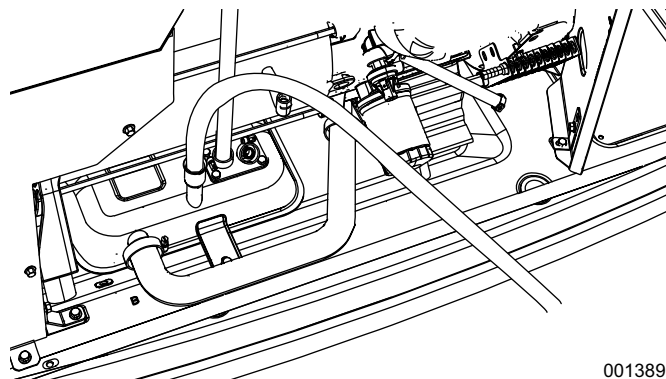

001389

**Figure 4-7. Drain Hose In Oil Tank**

11. See **Figure 4-8**. Insert  $\frac{1}{2}$  in hose free end into a suitable oil catch container. Verify there are no kinks or obstructions in either hose.

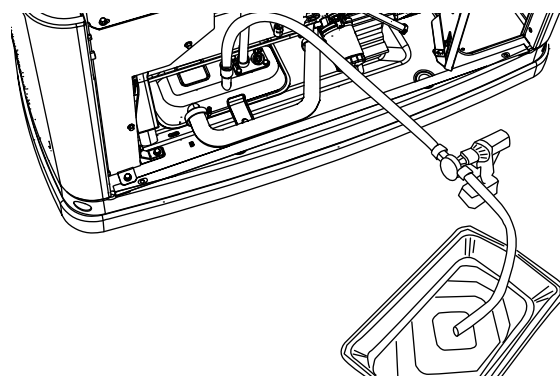

001390

**Figure 4-8. Draining Into Oil Catch Container**

12. Spin pump on drill high speed setting.

**NOTE:** It may take up to two minutes to prime the pump.

13. After oil begins pumping, draw out as much oil as possible. A total of 2.5–3.5 qts (2.37–3.31 L) of oil should be removed from the system.
14. Remove ¼ in hose from tank and drain remaining oil from drill pump and hoses.
15. Apply a light coating of new oil to gasket of new oil filter.
16. Screw new oil filter on by hand until filter gasket contacts oil filter adapter. Tighten new oil filter three-quarters to one full turn more.
17. Fill oil tank with recommended oil. Do not fill above full mark on dipstick.
18. Start engine, run for one minute and inspect for leaks.
19. Stop engine for a minimum of 10 minutes.
20. Check oil level and add oil if necessary.
21. Set generator MLCB (generator disconnect) to ON (CLOSED).
22. Press AUTO button on control panel.

Dispose of used engine oil and oil filter in accordance with national, state, or local codes.

## Replacing Engine Air Filter

Proceed as follows to service the air cleaner:

1. Lift lid and press OFF button on control panel to stop generator.
2. Remove front panel.
3. See [Figure 4-9](#). Remove cover clips (A) and air cleaner cover (B).

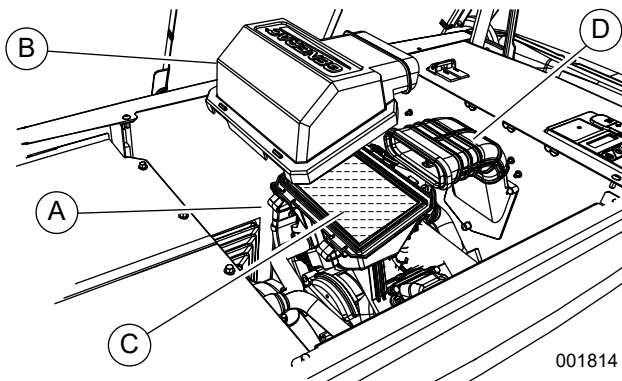

**Figure 4-9. Service Air Cleaner**

4. Remove old air filter element (C) and discard. Thoroughly clean air cleaner enclosure of dust and debris.
5. Install new air filter element.
6. Install air cleaner cover and fasten cover clips.
7. Verify air inlet duct (D) is correctly connected to air cleaner cover.
8. Press AUTO button on control panel to return unit to AUTO.

## Spark Plugs



### WARNING

Electric shock. Do not disconnect spark plug wires with engine running. Doing so could result in death or serious injury.

(000140a)

Inspect and replace spark plugs as necessary.

Proceed as follows to inspect spark plug gap(s) and replace spark plugs as necessary:

1. With generator OFF and engine cool, lift lid and remove front panel.
2. Clean area around spark plug bases to keep dirt and debris out of the engine.
3. Remove spark plugs and inspect condition. Install new plugs if existing plugs are worn or if reuse is questionable.
4. Clean each plug by scraping or washing with a wire brush and commercial solvent. Do not blast spark plugs to clean.

**NOTE:** Clean spark plug in emergency situations only. Otherwise, replace spark plug.

5. See [Figure 4-10](#). Inspect spark plug gap using a wire feeler gauge.

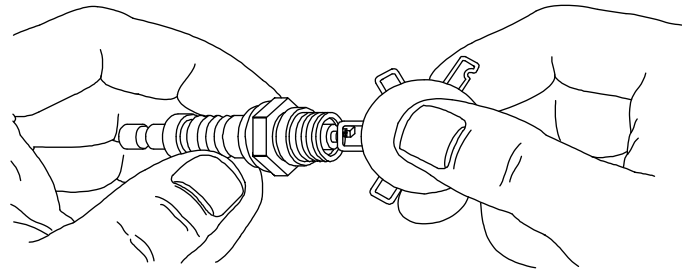

000211

**Figure 4-10. Check Spark Plug Gap**

**NOTE:** Check gap on new spark plugs prior to installation.

6. Replace spark plug if gap is out of specification. See [General Information](#).
7. Install spark plugs. Tighten to 18.4 ft-lb (25 Nm).
8. Press AUTO button to return unit to AUTO mode.

## Valve Clearance Adjustment

**IMPORTANT NOTE:** Contact an IASD for service assistance. Correct valve clearance is essential for prolonging the life of the engine.

Check valve clearance after the first 25 hours of operation, then after 500 hour intervals. Adjust if necessary. (See [Service Schedule](#)).

### Checking Valve Clearance

**NOTE:** Engine should be cool before checking valve clearance. Adjustment is not needed if valve clearance is within the dimensions provided in [Engine](#).

Proceed as follows to check valve clearance:

1. Close fuel valve and disconnect battery to avoid accidental start-up.
2. Remove spark plug wires, and position spark plug wires away from spark plugs.
3. Remove spark plugs.
4. Remove four screws attaching valve cover. Remove and discard gasket. (Repeat for second cylinder, if equipped.)
5. Verify piston is at top dead center (TDC) of its compression stroke (both valves closed).

**NOTE:** To move the piston to TDC, remove intake baffle at front of engine to access flywheel nut. Use a large socket and socket wrench to rotate flywheel nut clockwise, which will rotate the crankshaft. Watch piston through spark plug hole. Piston should move up and down. Piston is at TDC when it is at its highest point of travel.

6. See [Figure 4-11](#). Check valve clearance between each rocker arm (E) and valve stem (F) with a feeler gauge.

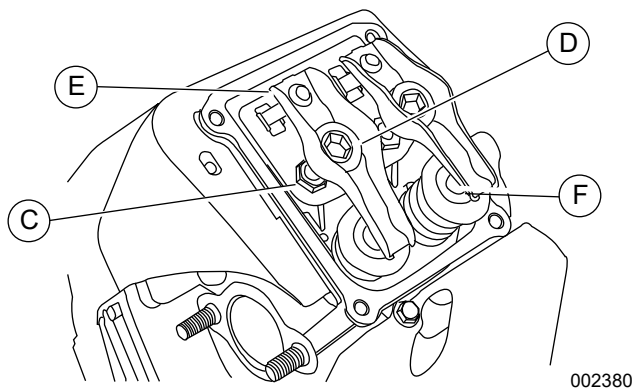

**Figure 4-11. Valve Clearance Adjustment**

7. Install replacement valve cover gasket(s).
8. Install valve cover. Tighten fasteners in a cross pattern, tightening to 60 **in-lbs** (6.8 Nm).
9. Remove spark plug cables from spark plug terminals.

10. Remove spark plugs.

11. Verify piston is at top dead center (TDC) of its compression stroke (both valves closed).

### Adjust Valve Clearance

See [Figure 4-11](#). Proceed as follows to adjust valve clearance:

**NOTE:** Allow engine to cool before adjusting valve clearance.

1. Remove spark plug wires and position spark plug wires away from spark plugs.
2. Remove spark plugs.
3. Remove four screws attaching valve cover. Remove and discard gasket.
4. Verify piston is at top dead center (TDC) of its compression stroke (both valves closed).
5. Loosen rocker jam nut (C) using a 13 mm wrench.
6. Turn pivot ball stud (D) using a 10 mm hex key while checking clearance between rocker arm (E) and valve stem (F) with a feeler gauge. Adjust clearance as per [Engine](#).

**NOTE:** Hold the rocker jam nut in place as the pivot ball stud is turned.

7. When valve clearance is correct, hold pivot ball stud (D) in place with a wrench and tighten rocker arm jam nut. Tighten jam nut to 174 **in-lbs** (19.68 Nm).
8. Verify valve clearance did not change.
9. Install new valve cover gasket.
10. Install valve cover. Tighten fasteners in a cross pattern, tightening to 60 **in-lbs** (6.8 Nm).

**NOTE:** Start all four screws before tightening, or it will not be possible to get all the screws in place. Verify the valve cover gasket is in place.

11. Install spark plugs and tighten to 18 ft-lbs (25 Nm).
12. Attach spark plug wire to spark plug.
13. Repeat the process for the other cylinder.

## Battery Maintenance



**DANGER**

Electrocution. Do not wear jewelry while working on this equipment. Doing so will result in death or serious injury.

(000188)



**WARNING**

Explosion. Do not dispose of batteries in a fire. Batteries are explosive. Electrolyte solution can cause burns and blindness. If electrolyte contacts skin or eyes, flush with water and seek immediate medical attention. (000162)



**WARNING**

Explosion. Batteries emit explosive gases while charging. Keep fire and spark away. Wear protective gear when working with batteries. Failure to do so could result in death or serious injury. (000137a)



**WARNING**

Electrical shock. Disconnect battery ground terminal before working on battery or battery wires. Failure to do so could result in death or serious injury. (000164)



**WARNING**

Risk of burns. Batteries contain sulfuric acid and can cause severe chemical burns. Wear protective gear when working with batteries. Failure to do so could result in death or serious injury. (000138a)



**WARNING**

Risk of burn. Do not open or mutilate batteries. Batteries contain electrolyte solution which can cause burns and blindness. If electrolyte contacts skin or eyes, flush with water and seek immediate medical attention. (000163a)

**WARNING**

Environmental Hazard. Always recycle batteries at an official recycling center in accordance with all local laws and regulations. Failure to do so could result in environmental damage, death, or serious injury. (000228)

Always recycle batteries in accordance with local laws and regulations. Contact your local solid waste collection site or recycling facility to obtain information on local recycling processes. For more information on battery recycling, visit the Battery Council International website at: <http://batteryCouncil.org>.

Strictly observe the following precautions when working on batteries:

- Remove 7.5 A fuse from generator control panel.
- Disconnect battery charger as directed in [Battery Maintenance](#).
- Use tools with insulated handles.
- Wear rubber gloves and boots.

- Do not place tools or metallic objects on top of battery.
- Disconnect charging source prior to connecting or disconnecting battery terminals.
- Wear full eye protection and protective clothing.
- If electrolyte contacts the skin, wash it off immediately with water.
- If electrolyte contacts the eyes, thoroughly flush with water immediately and seek medical attention.
- Wash down spilled electrolyte with an acid neutralizing agent. A common practice is to use a solution of 1 lb (454 g) bicarbonate of soda to 1 gal (3.8 L) of water. Add bicarbonate of soda solution until the evidence of reaction (foaming) has ceased. Flush the resulting liquid with water and dry the area completely.
- DO NOT smoke near battery.
- Discharge static electricity from the body before touching the battery by first touching a grounded metal surface.

The battery should be regularly inspected per the [Service Schedule](#). Contact an IASD for assistance if necessary.

**Inspecting the Battery**

Proceed as follows to inspect the battery:

1. Press OFF button to shut down generator, then lift lid and remove front panel.
2. Remove 7.5A fuse from control panel.
3. Remove intake side panel. (See [Intake Side Panel Removal](#).)
4. See [Figure 4-12](#). Inspect battery posts and cables for tightness and corrosion. Tighten and clean as necessary.

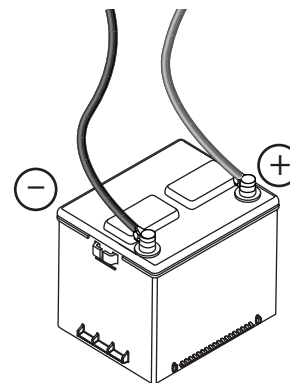

001832

**Figure 4-12. Battery Cables**

5. **Unsealed batteries only:** Completely disconnect battery. Check battery fluid level and, if necessary, fill with distilled water only. DO NOT use tap water. Have an IASD or a qualified service technician check the state of charge and condition.

- When inspection is complete, connect battery cables, install intake side panel, and install 7.5A fuse.
- Press AUTO button on controller.
- Install front panel and close generator lid.

## Cleaning the Sediment Trap

A sediment trap removes contaminants (moisture and fine particles) from gaseous fuels before they enter the fuel regulator. Accumulated moisture and particles must be emptied from sediment trap per local codes and guidelines.

Proceed as follows to clean the sediment trap:

- Remove intake side panel (see [Intake Side Panel Removal](#)).
- Turn generator fuel supply OFF.
- See [Figure 4-13](#). Unscrew and remove cap (A).

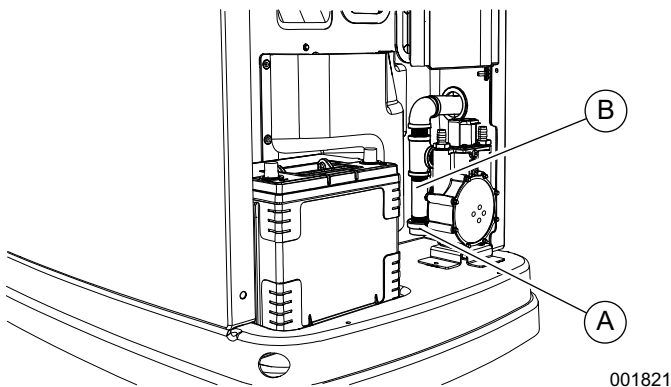

**Figure 4-13. Cleaning the Sediment Trap**

- Use a clean-out tool (not provided) to remove accumulated moisture and particles from cap and body (B).
- Wipe inside of each component with a clean, dry, lint-free cloth.
- Seal cap threads with appropriate sealing compound. Install cap and hand-tighten.
- Tighten cap with an appropriately sized pipe wrench. DO NOT overtighten.
- Turn generator fuel supply ON. Inspect for leaks by spraying all connection points with a non-corrosive gas leak detection fluid. Solution should not be blown away or form bubbles.
- Install intake side panel.

## Post Maintenance Checks

Proceed as follows to perform post maintenance checks:

- Perform required maintenance procedure(s).
- Install intake side panel and front panel if removed. (See [Intake Side Panel Removal](#) and [Front Access Panel Removal](#).)
- Install 7.5A fuse in control panel.

- Complete Install Wizard information.
- Press AUTO button on control panel. Allow unit to run for one minute with no load (if running during a utility outage).
- Set generator MLCB (generator disconnect) to ON (CLOSED).
- Set utility MLCB to ON (CLOSED).

The system is now in automatic mode.

**NOTE:** If utility is present at this time, the generator will perform its usual shutdown process.

## Performing Fuel System Leak Test



**⚠ DANGER**

Explosion and fire. Fuel and vapors are extremely flammable and explosive. No leakage of fuel is permitted. Keep fire and spark away. Failure to do so will result in death or serious injury. (000192)

All products are factory-tested before shipping to verify the performance and integrity of the fuel system. However, it is important to perform a final fuel system leak test before starting the generator. The entire fuel system should be tested from supply to regulator.

See [Figure 4-14](#). Perform a final fuel system leak test after generator installation. The test will identify possible leaks at all connection points (A).

It is best practice to perform a fuel system leak test during normally-scheduled maintenance.

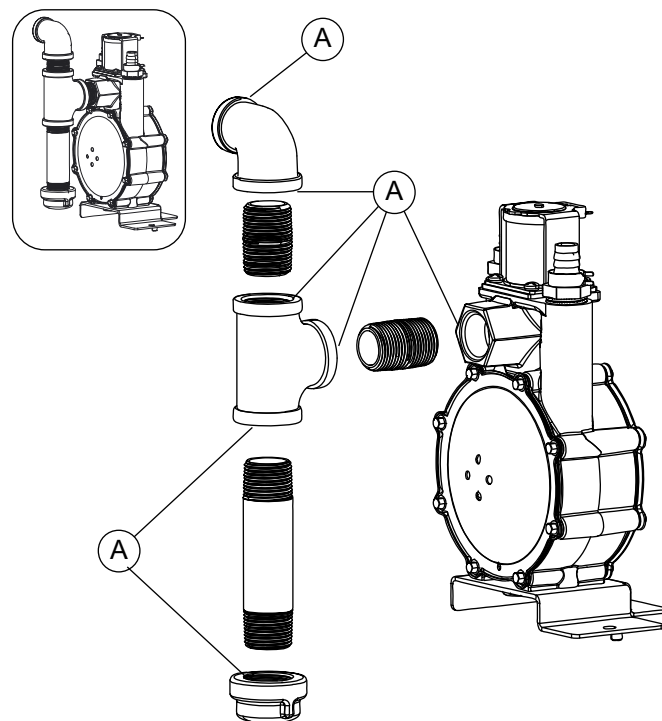

004038

**Figure 4-14. Connection Points to Leak Check**

Inspect for leaks by spraying all connection points with a non-corrosive gas leak detection fluid. The solution should not be blown away or form bubbles.

## Attention After Submersion

DO NOT start or operate generator if it has been submerged in water. Have an IASD thoroughly clean, dry, and inspect the generator following any submersion in water. If the structure (home) has been flooded, it should be inspected by a certified electrician to verify there will not be any electrical problems during generator operation or when utility power is returned.

## Corrosion Protection

Regular scheduled maintenance should be conducted to perform a visual inspection of the unit for corrosion. Inspect all metal components of the generator, including the base frame, brackets, alternator can, the entire fuel system (inside and outside of the generator), and fastener locations. If there is corrosion found on generator components (e.g. regulator, engine/alternator mounts, fuel plenum, etc.), replace parts as necessary.

Periodically wash and wax the enclosure using automotive type products. Do not spray the unit with a hose or power washer. Use warm, soapy water and a soft cloth. Frequent washing is recommended in salt water/coastal areas. Spray engine linkages with a light oil such as WD-40.

## Remove From, and Return To Service Procedure



### ⚠️ WARNING

Explosion. Batteries emit explosive gases. Always disconnect negative battery cable first to avoid spark. Failure to do so could result in death or serious injury. (000238)



### ⚠️ WARNING

Explosion. Batteries emit explosive gases. Always connect positive battery cable first to avoid spark. Failure to do so could result in death or serious injury. (000133)

## Remove From Service

If unit will be out of service longer than 90 days, proceed as follows to prepare the generator for storage:

1. Start engine and allow it to warm up.
2. Close fuel shutoff valve in the fuel supply line and allow engine to stop.
3. Once engine has stopped, set generator MLCB (generator disconnect) to OFF (OPEN).

4. Disconnect battery charger AC input T1/Neutral cable (with white sleeve) at controller.
5. Remove 7.5A fuse from generator control panel.
6. Disconnect battery cables. Remove negative battery cable first.
7. Drain oil completely while engine is still warm, and then fill with oil. See [Engine Oil Requirements](#).
8. Attach an engine tag indicating viscosity and classification of the new oil in the crankcase.
9. Remove spark plugs and spray a fogging agent into spark plugs threaded openings. Install and tighten spark plugs to specification.
10. Remove battery and store in a cool, dry place.
11. Clean and wipe down generator enclosure.

## Return to Service

Proceed as follows to return unit to service after storage:

1. Inspect engine tag for oil viscosity and classification. Drain and fill with correct oil, if necessary.
2. Check state of the battery. Fill all cells of unsealed batteries to the correct level with distilled water. DO NOT use tap water. Charge battery to FULL state of charge. Replace battery if completely discharged.
3. Clean and wipe down generator enclosure.
4. Verify 7.5A fuse is removed from generator control panel.
5. Connect battery. Observe battery polarity. Damage may occur if battery is connected incorrectly. Install positive battery cable first.
6. Connect battery charger AC input T1/Neutral cable (with white sleeve) at controller.
7. Open fuel shutoff valve.
8. Insert 7.5A fuse into generator control panel.
9. Complete Install Wizard procedure.
10. Press MANUAL button to start unit. Allow unit to warm up for a few minutes.
11. Press OFF mode button to stop unit.
12. Set generator MLCB (generator disconnect) to ON (CLOSED).
13. Press AUTO button on control panel.

Generator is ready for service.

**NOTE:** Current date and time must be reset if a battery has been completely discharged or disconnected.

# Section 5: Troubleshooting / Quick Reference Guide

## Generator Troubleshooting

Problem	Cause	Correction
Engine will not crank.	Blown fuse.	Correct short circuit condition by replacing 7.5 A fuse in generator control panel. Contact an IASD if fuse continues to blow.
	Loose, corroded, or faulty battery cables.	Tighten, clean, or replace as necessary.*
	Faulty starter contact.	
	Faulty starter motor.	
	Discharged battery.	Charge or replace battery.
Engine cranks but will not start	No fuel.	Replenish fuel / turn on fuel valve.
	Faulty fuel solenoid (FS).	Contact an IASD for assistance.
	Harness/wiring issue.	
	Faulty spark plugs.	Clean; inspect spark plug gap; replace spark plugs if necessary.
	Valve clearance out of adjustment.	Adjust valve clearance.
Engine starts hard and runs rough	Air cleaner plugged or damaged.	Inspect and clean air cleaner.
	Faulty spark plugs.	Clean; inspect spark plug gap; replace spark plugs if necessary.
	Incorrect fuel pressure.	Verify fuel pressure to regulator is 10–12 in water column (2.5–3.0 kPa) for LP, and 3.5–7.0 in water column (0.87–1.7 kPa) for NG.
	Fuel selector in wrong position.	Set fuel conversion valve to correct position.
	Valve(s) out of adjustment.	Adjust valve clearance.
	Internal engine issue.	Contact an IASD for assistance.
Generator is set to OFF, but the engine continues to run	Controller wired incorrectly.	Contact an IASD for assistance.
	Faulty control board.	
No AC output from generator	Generator MLCB (generator disconnect) is OFF (OPEN).	Set generator MLCB (generator disconnect) to ON (CLOSED).
	Generator internal failure.	Contact an IASD for assistance.
	Engine may be warming up. See <b>Cold Smart Start</b> .	Check controller screen to verify status.

Problem	Cause	Correction
No transfer to standby after utility source failure	Generator MLCB (generator disconnect) is OFF (OPEN).	Set generator MLCB (generator disconnect) to ON (CLOSED).
	Faulty transfer switch coil.	Contact an IASD for assistance.
	Faulty transfer relay.	
	Transfer relay circuit open.	
	Faulty control logic board.	Check controller screen to verify status.
Engine may be warming up. See <b>Cold Smart Start</b> .		
Unit consumes large amounts of oil	Excessive engine oil.	Adjust oil to correct level.
	Faulty engine breather.	Contact an IASD for assistance.
	Incorrect type or viscosity of oil	See <b>Engine Oil Requirements</b> .
	Damaged gasket, seal, or hose.	Inspect for oil leaks.
	Restricted air filter.	Replace air filter.
Wi-Fi connection broken or intermittent	Various.	See Wi-Fi module owner's manual.
* Contact an IASD for assistance.		

**NOTE:** IASD must have an active Tech ID and be air-cooled certified to perform any warrantable repairs and submit warranty claims related to air-cooled products.

## Quick Reference Guide

To clear an active alarm, press the OFF mode button on the control panel, then the ENTER button, and finally the AUTO mode button. Contact an air-cooled certified IASD if the alarm reoccurs.

Active Alarm	LED	Problem	Actions	Solution
NONE	FLASHING GREEN	Unit running in AUTO but no power in house.	Check generator MLCB (generator disconnect).	If generator MLCB (generator disconnect) is ON, contact an IASD.
HIGH TEMPERATURE	RED	Unit shuts down during operation.	Check LEDs / screen for alarms.	Inspect ventilation around generator, intake, exhaust, and rear of generator. If no obstructions are present, contact an IASD.
OVERLOAD REMOVE LOAD	RED	Unit shuts down during operation.	Check LEDs / screen for alarms.	Clear alarm and remove household loads from generator. Put in AUTO and restart.
RPM SENSE LOSS	RED	Unit was running and shut down, attempts to restart.	Check LEDs / screen for alarms.	Clear alarm and remove household loads from generator. Put into AUTO and restart. If generator does not start, contact an IASD.
NOT ACTIVATED	NONE	Unit will not start in AUTO with utility loss.	Check if screen says unit not activated.	See "Activation" in installation manual.
NONE	GREEN	Unit will not start in AUTO with utility loss.	Check screen for start delay countdown.	If startup delay is greater than expected, contact an IASD to adjust from 2 to 1500 seconds.
LOW OIL PRESSURE	RED	Unit will not start in AUTO with utility loss.	Check LEDs / screen for alarms.	Check oil level and add oil as needed. If oil level is correct, contact an IASD.
RPM SENSE LOSS	RED	Unit will not start in AUTO with utility loss.	Check LEDs / screen for alarms.	Clear alarm. Using the control panel, check battery by navigating to BATTERY MENU option from the MAIN MENU. If battery condition displays GOOD, contact an IASD. If control panel displays CHECK BATTERY, replace battery.
OVERCRANK	RED	Unit will not start in AUTO with utility loss.	Check LEDs / screen for alarms.	Check fuel line shutoff valve is ON. Clear alarm. Start the unit in MANUAL. If it does not start, or starts and runs rough, contact an IASD.
LOW VOLTS REMOVE LOAD	RED	Unit will not start in AUTO with utility loss.	Check LEDs / screen for alarms.	Clear alarm and remove household loads from the generator. Put in AUTO and restart.
OVERSPEED	RED	Unit will not start in AUTO with utility loss.	Check LEDs / screen for alarms.	Contact an IASD.
UNDERVOLTAGE	RED	Unit will not start in AUTO with utility loss.	Check LEDs / screen for alarms.	Contact an IASD.
UNDERSPEED	RED	Unit will not start in AUTO with utility loss.	Check LEDs / screen for alarms.	Contact an IASD.
STEPPER OVERCURRENT	RED	Unit will not start in AUTO with utility loss.	Check LEDs / screen for alarms.	Contact an IASD.
WIRING ERROR	RED	Unit will not start in AUTO with utility loss.	Check LEDs / screen for alarms.	Contact an IASD.
OVERVOLTAGE	RED	Unit will not start in AUTO with utility loss.	Check LEDs / screen for alarms.	Contact an IASD.

<b>Active Alarm</b>	<b>LED</b>	<b>Problem</b>	<b>Actions</b>	<b>Solution</b>
SHUTDOWN SWITCH	RED	Unit will not start.	Check emergency shutdown switches	Set emergency shutdown switch(es) to CLOSED (I). Clear alarm.
LOW BATTERY	YELLOW	Yellow LED illuminated in any state.	Check the screen for additional information.	Clear alarm. Using the control panel, check battery by navigating to BATTERY MENU option from the MAIN MENU. If battery condition displays GOOD, contact an IASD. If control panel displays CHECK BATTERY, replace battery.
BATTERY PROBLEM	YELLOW	Yellow LED illuminated in any state.	Check screen for additional information.	Contact an IASD.
CHARGER WARNING	YELLOW	Yellow LED illuminated in any state.	Check screen for additional information.	Contact an IASD.
CHARGER MISSING AC	YELLOW	Yellow LED illuminated in any state.	Check screen for additional information.	Contact an IASD.
SERVICE A	YELLOW	Yellow LED illuminated in any state.	Check screen for additional information.	Perform SERVICE A maintenance. Press ENTER to clear.
SERVICE B	YELLOW	Yellow LED illuminated in any state.	Check screen for additional information.	Perform SERVICE B maintenance. Press ENTER to clear.
INSPECT BATTERY	YELLOW	Yellow LED illuminated in any state.	Check screen for additional information.	Inspect battery. Press ENTER to clear.

**This page intentionally left blank.**

**This page intentionally left blank.**



Part No. 1000032217 Rev. D 06/12/2023  
©2023 Generac Power Systems, Inc.  
All rights reserved.  
Specifications are subject to change without notice.  
No reproduction allowed in any form without prior written  
consent from Generac Power Systems, Inc.

**GENERAC®**



Generac Power Systems, Inc.  
S45 W29290 Hwy. 59  
Waukesha, WI 53189  
1-888-GENERAC (1-888-436-3722)  
[www.generac.com](http://www.generac.com)