

Owner's Manual 60 Hz Air-Cooled Generators

9 kW to 22 kW

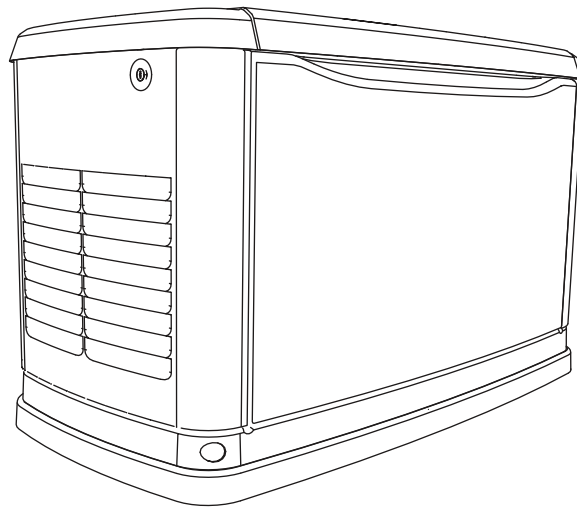

WARNING

This product is not intended to be used in a critical life support application. Failure to adhere to this warning could result in death or serious injury. (000209a)

Register your Generac product at:
WWW.GENERAC.COM
1-888-GENERAC
(888-436-3722)

Para español, visita: <http://www.generac.com/service-support/product-support-lookup>

Pour le français, visiter : <http://www.generac.com/service-support/product-support-lookup>

SAVE THIS MANUAL FOR FUTURE REFERENCE

Use this page to record important information about your generator set.

Model:	
Serial:	
Prod Date Week:	
Volts:	
LPV Amps:	
NG Amps:	
Hz:	
Phase:	
Controller P/N:	

Record the information found on your unit data label on this page. See **General Information** for the location of the unit data label. The unit has a label plate affixed to the inside partition, to the left of the control panel console as shown in **Figure 2-1**. See **Operation** for directions on how to open the top lid and remove the front panel.

When contacting an Independent Authorized Service Dealer (IASD) about parts and service, always supply the complete model and serial numbers of the unit.

Operation and Maintenance: Proper maintenance and care of the generator ensures a minimum number of problems and keeps operating expenses at a minimum. It is the operator's responsibility to perform all safety checks, to make sure that all maintenance for safe operation is performed promptly, and to have the equipment checked periodically by an IASD. Normal maintenance, service, and replacement of parts are the responsibility of the owner/operator and are not considered defects in materials or workmanship within the terms of the warranty. Individual operating habits and usage may contribute to the need for additional maintenance or service.

When the generator requires servicing or repairs, Generac recommends contacting an Independent Authorized Service Dealer for assistance. Authorized service technicians are factory-trained and are capable of handling all service needs. To locate the nearest Independent Authorized Service Dealer, please visit the dealer locator at:

www.generac.com/Service/DealerLocator/

! WARNING

California Proposition 65. Engine exhaust and some of its constituents are known to the state of California to cause cancer, birth defects, and other reproductive harm. (000004)

! WARNING

California Proposition 65. This product contains or emits chemicals known to the state of California to cause cancer, birth defects, and other reproductive harm. (000005)

Table of Contents

Section 1: Safety Rules & General Information

Introduction	1
Read This Manual Thoroughly	1
How to Obtain Service	1
Safety Rules	1
General Hazards	2
Exhaust Hazards	3
Electrical Hazards	3
Fire Hazards	4
Explosion Hazards	4

Section 2: General Information

The Generator	5
Specifications	7
Generator	7
Engine	7
Protection Systems	8
Emission Information	8
Fuel Requirements	8
Battery Requirements	8
Battery Charger	8
Engine Oil Requirements	8
Activating the Generator	9
Replacement Parts	9
Accessories	9

Section 3: Operation

Site Prep Verification	11
Generator Enclosure	11
Opening the Lid	11
Removing the Front Access Panel	11
Intake Side Panel Removal	12
Main Line Circuit Breaker (Generator Disconnect)	12
LED Indicator Lights	12
Control Panel Interface	13
Using the AUTO/OFF/MANUAL Interface	13
Interface Menu Displays	13
The LCD Panel	13
Menu System Navigation	14

Setting the Exercise Timer	16
Battery Charger	16
Manual Transfer Operation	17
Transfer to Generator Power Source	17
Transfer to Utility Power Source	18
Automatic Transfer Operation	18
Automatic Sequence of Operation	18
Utility Failure	18
Cranking	18
Cold Smart Start	19
Load Transfer	19
Shutting Generator Down While Under Load Or During An Extended Outage	19
To turn the generator OFF:	19
To turn the generator back ON:	19

Section 4: Maintenance

Maintenance	23
Preparing for Maintenance	23
Performing Scheduled Maintenance	23
Service Schedule	24
Maintenance Log	24
Checking Engine Oil Level	25
Engine Oil Requirements	25
Changing the Oil and Oil Filter	26
Servicing the Air Cleaner	26
Spark Plugs	27
Valve Clearance Adjustment	27
Check Valve Clearance	27
Adjust Valve Clearance	27
Battery Maintenance	28
Cleaning the Sediment Trap	29
Attention After Submersion	29
Corrosion Protection	30
Remove From, and Return To Service	30
Remove From Service	30
Return to Service	30

**Section 5: Troubleshooting / Quick
Reference Guide**

Generator Troubleshooting31
Quick Reference Guide32

Section 1: Safety Rules & General Information

Introduction

Thank you for purchasing this compact, high performance, air-cooled, engine-driven generator. It is designed to automatically supply electrical power to operate critical loads during a utility power failure.

This unit is factory installed in an all-weather, metal enclosure that is intended exclusively for outdoor installation. This generator will operate using either vapor withdrawn liquid propane (LP) or natural gas (NG).

NOTE: This generator is suitable for supplying typical residential loads such as induction motors (sump pumps, refrigerators, air conditioners, furnaces, etc.), electronic components (computer, monitor, TV, etc.), lighting loads, and microwaves, when sized properly.

Read This Manual Thoroughly



WARNING

Consult Manual. Read and understand manual completely before using product. Failure to completely understand manual and product could result in death or serious injury. (000100a)

If any portion of this manual is not understood, contact the nearest Independent Authorized Service Dealer (IASD) for starting, operating, and servicing procedures.

This manual must be used in conjunction with the appropriate installation manual.

SAVE THESE INSTRUCTIONS: The manufacturer suggests that this manual and the rules for safe operation be copied and posted near the unit installation site. Safety should be stressed to all operators and potential operators of this equipment.

Throughout this publication and on tags and decals affixed to the generator, DANGER, WARNING, and CAUTION blocks are used to alert personnel to special instructions about a particular operation that may be hazardous if performed incorrectly or carelessly. Observe them carefully. Their definitions are as follows:

DANGER

Indicates a hazardous situation which, if not avoided, will result in death or serious injury.

(000001)

WARNING

Indicates a hazardous situation which, if not avoided, could result in death or serious injury.

(000002)

CAUTION

Indicates a hazardous situation which, if not avoided, could result in minor or moderate injury.

(000003)

NOTE: Notes provide additional information important to a procedure or component.

These safety alerts cannot eliminate the hazards they indicate. Observing safety precautions and strict compliance with the special instructions while performing the action or service are essential to preventing accidents.

The operator is responsible for proper and safe use of the equipment. The manufacturer strongly recommends that if the operator is also the owner, to read the owner's manual and thoroughly understand all instructions before using this equipment. The manufacturer also strongly recommends instructing other users to properly start and operate the unit. This prepares them if they need to operate the equipment in an emergency.

How to Obtain Service

Contact an IASD for assistance when the generator requires servicing or repairs. Service technicians are factory-trained and are capable of handling all service needs. Please visit the dealer locator at: www.generac.com/Service/DealerLocator/ to locate the nearest IASD.

When contacting a dealer about parts and service, always supply the complete model and serial numbers of the unit as given on its data plate (decals), which is located on the generator. See *Figure 2-1* for decal location. Record the model and serial numbers in the spaces provided on the inside front cover of this manual.

Safety Rules

Study these SAFETY RULES carefully before installing, operating, or servicing this equipment. Become familiar with this owner's manual and with the unit. The generator can operate safely, efficiently, and reliably only if it is properly installed, operated, and maintained. Many accidents are caused by failing to follow simple and fundamental rules or precautions.

The manufacturer cannot anticipate every possible circumstance that might involve a hazard. The alerts in this manual and on tags and decals affixed to the unit are not all-inclusive. If using a procedure, work method, or operating technique the manufacturer does not specifically recommend, verify that it is safe for others and does not render the generator unsafe.

General Hazards

⚠ DANGER

Loss of life. Property damage. Installation must always comply with applicable codes, standards, laws and regulations. Failure to do so will result in death or serious injury. (000190)

⚠ DANGER

Automatic start-up. Disconnect utility power and render unit inoperable before working on unit. Failure to do so will result in death or serious injury. (000191)



⚠ WARNING

This product is not intended to be used in a critical life support application. Failure to adhere to this warning could result in death or serious injury. (000209a)

⚠ WARNING

This unit is not intended for use as a prime power source. It is intended for use as an intermediate power supply in the event of temporary power outage only. See individual unit specifications for required maintenance and run times pertaining to use. (000247)

⚠ WARNING

Accidental Start-up. Disconnect the negative battery cable, then the positive battery cable when working on unit. Failure to do so could result in death or serious injury. (000130)

⚠ WARNING

Only qualified service personnel may install, operate and maintain this equipment. Failure to follow proper installation requirements could result in death, serious injury, and damage to equipment or property. (000182)



⚠ WARNING

Electrocution. Potentially lethal voltages are generated by this equipment. Render the equipment safe before attempting repairs or maintenance. Failure to do so could result in death or serious injury. (000187)

⚠ WARNING

Only a trained and licensed electrician should perform wiring and connections to unit. Failure to follow proper installation requirements could result in death, serious injury, and damage to equipment or property. (000155)



⚠ WARNING

Moving Parts. Do not wear jewelry when starting or operating this product. Wearing jewelry while starting or operating this product could result in death or serious injury. (000115)



⚠ WARNING

Moving Parts. Keep clothing, hair, and appendages away from moving parts. Failure to do so could result in death or serious injury. (000111)



⚠ WARNING

Hot Surfaces. When operating machine, do not touch hot surfaces. Keep machine away from combustibles during use. Hot surfaces could result in severe burns or fire. (000108)

⚠ WARNING

Equipment and property damage. Do not alter construction of, installation, or block ventilation for generator. Failure to do so could result in unsafe operation or damage to the generator. (000146)

⚠ WARNING

Risk of injury. Do not operate or service this machine if not fully alert. Fatigue can impair the ability to service this equipment and could result in death or serious injury. (000215)

⚠ WARNING

Environmental Hazard. Always recycle batteries at an official recycling center in accordance with all local laws and regulations. Failure to do so could result in environmental damage, death or serious injury. (000228)

⚠ WARNING

Injury and equipment damage. Do not use generator as a step. Doing so could result in falling, damaged parts, unsafe equipment operation, and could result in death or serious injury. (000216)

- Inspect the generator regularly, and contact the nearest IASD for parts needing repair or replacement.

Exhaust Hazards



⚠ DANGER

Asphyxiation. Running engines produce carbon monoxide, a colorless, odorless, poisonous gas. Carbon monoxide, if not avoided, will result in death or serious injury. (000103)



⚠ WARNING

Asphyxiation. Always use a battery operated carbon monoxide alarm indoors and installed according to the manufacturer's instructions. Failure to do so could result in death or serious injury. (000178a)

⚠ WARNING

Equipment and property damage. Do not alter construction of, installation, or block ventilation for generator. Failure to do so could result in unsafe operation or damage to the generator. (000146)

- The generator must be installed and operated outdoors only.

Electrical Hazards



⚠ DANGER

Electrocution. Contact with bare wires, terminals, and connections while generator is running will result in death or serious injury. (000144)



⚠ DANGER

Electrocution. Never connect this unit to the electrical system of any building unless a licensed electrician has installed an approved transfer switch. Failure to do so will result in death or serious injury. (000150)

⚠ DANGER

Electrical backfeed. Use only approved switchgear to isolate generator from the normal power source. Failure to do so will result in death, serious injury, and equipment damage. (000237)



⚠ DANGER

Electrocution. Verify electrical system is properly grounded before applying power. Failure to do so will result in death or serious injury. (000152)



⚠ DANGER

Electrocution. Do not wear jewelry while working on this equipment. Doing so will result in death or serious injury. (000188)



⚠ DANGER

Electrocution. Water contact with a power source, if not avoided, will result in death or serious injury. (000104)



⚠ DANGER

Electrocution. In the event of electrical accident, immediately shut power OFF. Use non-conductive implements to free victim from live conductor. Apply first aid and get medical help. Failure to do so will result in death or serious injury. (000145)

Fire Hazards



⚠️ WARNING

Fire hazard. Do not obstruct cooling and ventilating airflow around the generator. Inadequate ventilation could result in fire hazard, possible equipment damage, death or serious injury. (000217)



⚠️ WARNING

Fire and explosion. Installation must comply with all local, state, and national electrical building codes. Noncompliance could result in unsafe operation, equipment damage, death or serious injury. (000218)



⚠️ WARNING

Fire hazard. Use only fully-charged fire extinguishers rated "ABC" by the NFPA. Discharged or improperly rated fire extinguishers will not extinguish electrical fires in automatic standby generators. (000219)



⚠️ WARNING

Consult Manual. Read and understand manual completely before using product. Failure to completely understand manual and product could result in death or serious injury. (000100a)



⚠️ WARNING

Electrocution. Refer to local codes and standards for safety equipment required when working with a live electrical system. Failure to use required safety equipment could result in death or serious injury. (000257)



⚠️ WARNING

Risk of Fire. Unit must be positioned in a manner that prevents combustible material accumulation underneath. Failure to do so could result in death or serious injury. (000147)

- Comply with regulations the Occupational Safety and Health Administration (OSHA) has established. Also verify that the generator is installed in accordance with the manufacturer's instructions and recommendations. Following proper installation, do nothing that might alter a safe installation and render the unit in noncompliance with the aforementioned codes, standards, laws, and regulations.

Explosion Hazards



⚠️ DANGER

Explosion and Fire. Fuel and vapors are extremely flammable and explosive. No leakage of fuel is permitted. Keep fire and spark away. Failure to do so will result in death or serious injury. (000192)

⚠️ DANGER

Connection of fuel source must be done by a qualified professional technician or contractor. Incorrect installation of this unit will result in death, serious injury, and damage to equipment and property damage. (000151)



⚠️ DANGER

Risk of fire. Allow fuel spills to completely dry before starting engine. Failure to do so will result in death or serious injury. (000174)



⚠️ WARNING

Risk of Fire. Hot surfaces could ignite combustibles, resulting in fire. Fire could result in death or serious injury. (000110)

Section 2: General Information

The Generator

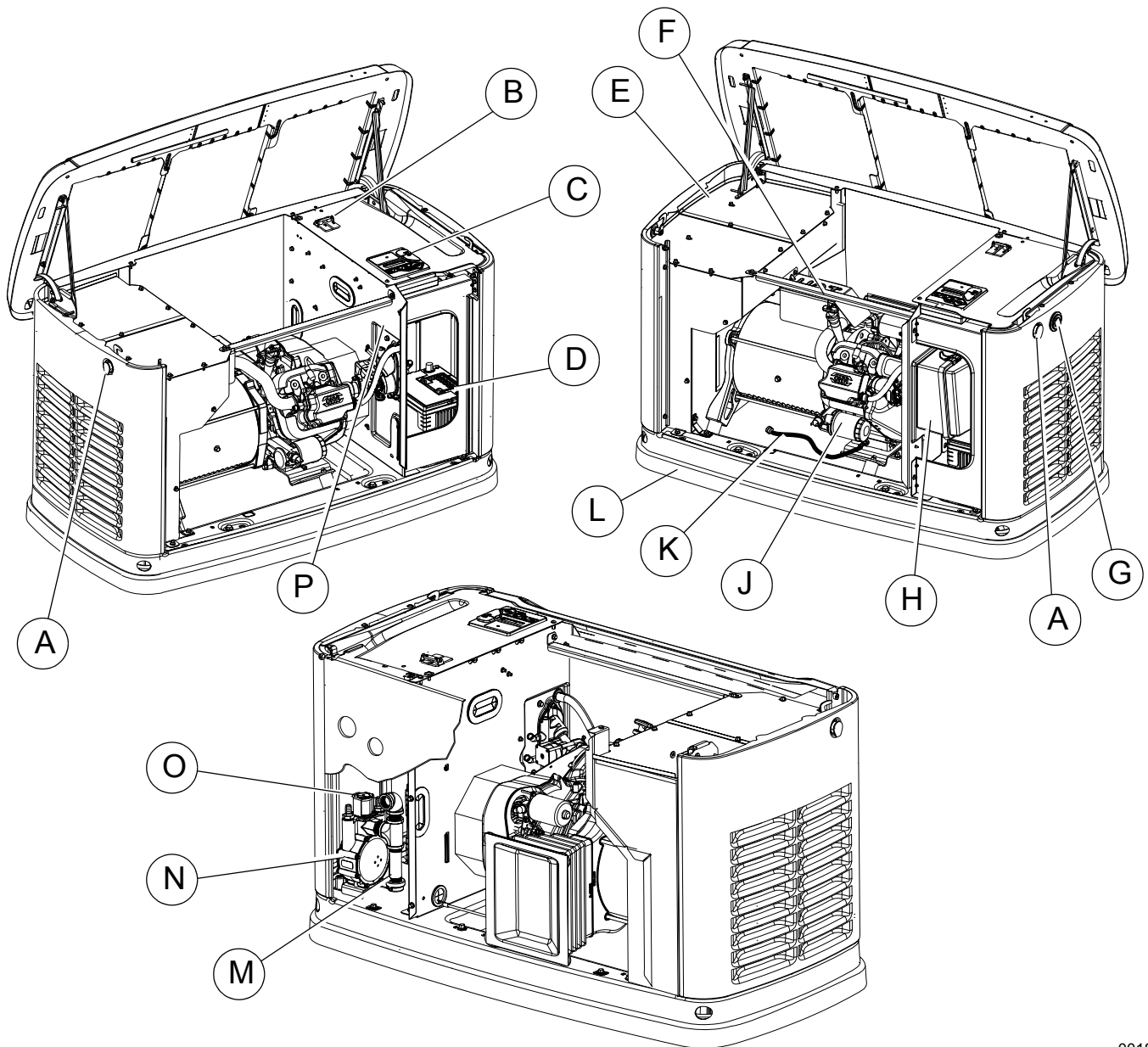

001818

Figure 2-1. 9kW—Components and Control Locations

A. Lock with Cover	E. Exhaust Enclosure	J. Oil Filter	N. Fuel Regulator
B. Main Line Circuit Breaker (Generator Disconnect)	F. Oil Fill Cap/Dipstick	K. Oil Drain Hose	O. Fuel Inlet
C. Control Panel	G. Status LED Indicators	L. Composite Base	P. Data Plate Location
D. Battery Compartment (Battery not supplied)	H. Airbox with Air Cleaner	M. Sediment Trap	

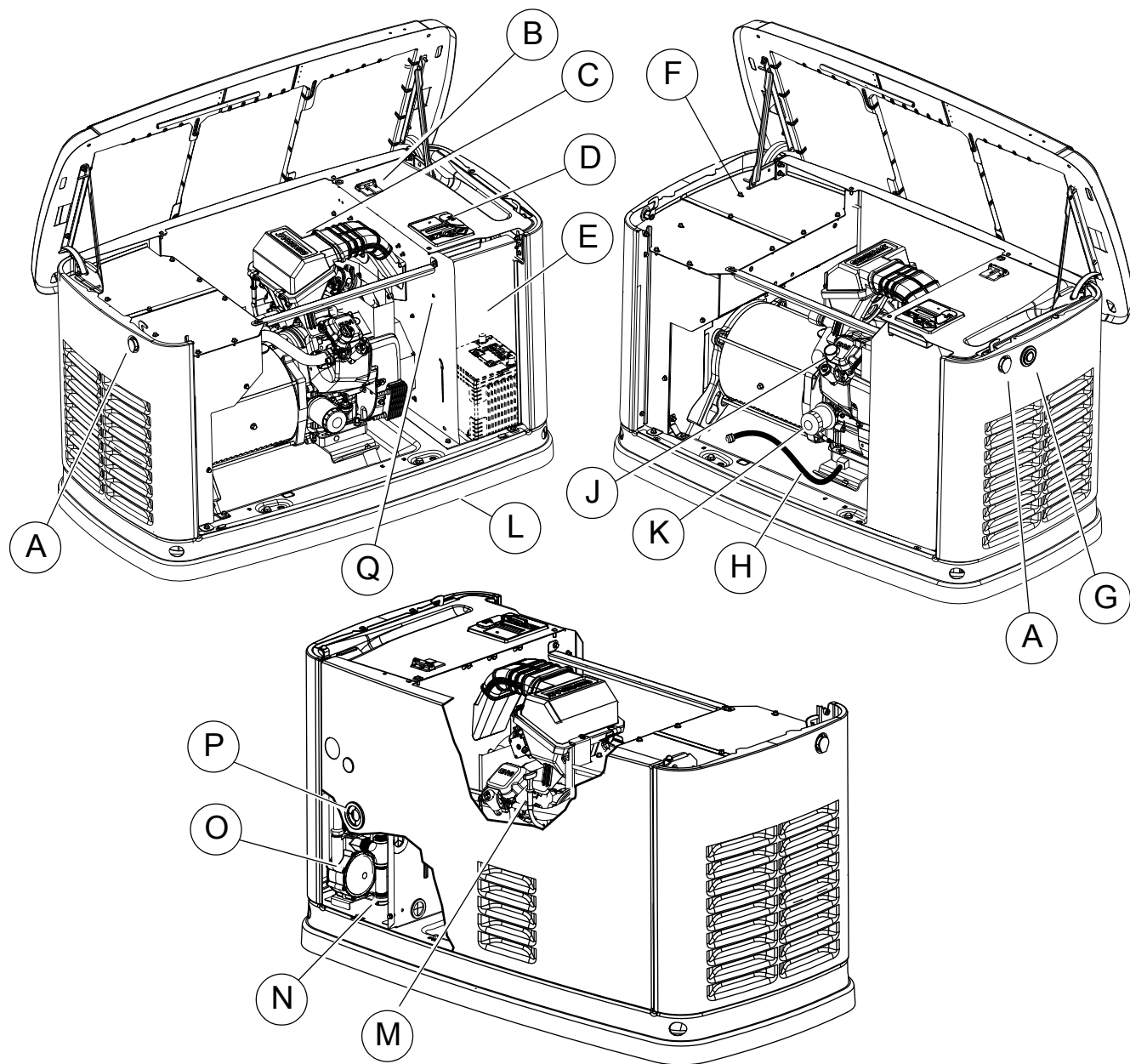

001786

Figure 2-2. 11kW–22kW—Components and Control Locations

- | | | | |
|------------------------------------------------------------|------------------------------------------------------|--------------------------|-------------------------------|
| A. Lock with Cover | E. Battery Compartment (Battery not supplied) | J. Oil Fill Cap | N. Sediment Trap |
| B. Main Line Circuit Breaker (Generator Disconnect) | F. Exhaust Enclosure | K. Oil Filter | O. Fuel Regulator |
| C. Airbox with Air Cleaner | G. Status LED Indicators | L. Composite Base | P. Fuel Inlet |
| D. Control Panel | H. Oil Drain | M. Oil Dipstick | Q. Data Plate Location |

Specifications

Generator

Model	9 kW	11 kW	16 kW	20 kW	22 kW
Rated Voltage	240				
Rated Maximum Load Current (Amps) at Rated Voltage with LP*	37.5	45.8	66.6	83.3	91.7
Main Line Circuit Breaker (Generator Disconnect)	40 Amp	50 Amp	70 Amp	100 Amp	100 Amp
Phase	1				
Rated AC Frequency	60 Hz				
Battery Requirement (Field supplied)	12 volts, Group 26R-540CCA Minimum or Group 35AGM-650CCA Minimum (see Replacement Parts)				
Enclosure	Aluminum				
Weight (lbs/kilos) (without battery)	340/154	348/158	409/186	448/203	466/211
Normal Operating Range	This unit is tested in accordance to UL 2200 standards with an operating temperature of -20 °F (-29 °C) to 122 °F (50 °C). For areas where temperatures fall below 32 °F (0 °C) a cold weather kit is recommended. When operated above 77 °F (25 °C) there may be a decrease in engine power. See Engine .				
These generators are rated in accordance with UL 2200, Safety Standard for Stationary Engine Generator Assemblies, and CSA-C22.2 No. 100-04 Standard for Motors and Generators.					
* Natural Gas ratings will depend on specific fuel joules/BTU content. Typical derates are between 10-20% off the LP gas rating.					

Engine

Model	9 kW	11 kW	16/20/22 kW
Type of Engine	GH-426	GTH-530	GT-999
Number of Cylinders	1	2	2
Displacement	426 cc	530 cc	999 cc
Cylinder Block	Aluminum w/ cast iron sleeve		
Recommended Spark Plug	See Replacement Parts		
Spark Plug Gap	0.020 in (0.508 mm)	0.030 in (0.76 mm)	0.040 in (1.02 mm)
Valve Clearance	0.002–0.004 in (0.05–0.1 mm)	0.002–0.004 in (0.05–0.1 mm)	0.002–0.004 in (0.05–0.1 mm)
Starter	12 VDC		
Oil Capacity Including Filter	Approx. 1.1 qt (1.03 L)	Approx. 1.7 qt (1.6 L)	Approx. 1.9 qt (1.8 L)
Recommended Oil Filter	See Replacement Parts		
Recommended Air Filter	See Replacement Parts		
Engine power is subject to and limited by such factors as fuel BTU/joules, ambient temperature and altitude. Engine power decreases about 3.5% for each 1000 ft (304.8 m) above sea level, and also will decrease about 1% for each 10 °F (6 °C) above 60 °F (15 °C) ambient temperature.			

The specification sheet for your generator was included in the documentation provided with the unit at the time of purchase. For additional copies, consult your local Independent Authorized Service Dealer (IASD) for your specific generator model.

Protection Systems

The generator may need to run for long periods of time with no operator present to monitor the engine/generator conditions. The generator is equipped with protection systems to automatically shut down the unit to protect against potentially damaging conditions. Some of these systems include:

Alarms:

- High Temperature
- Low Oil Pressure
- Overcrank
- Overspeed
- Overvoltage
- Undervoltage
- Overload
- Underspeed
- RPM Sensor Loss
- Controller Fault
- Wiring Error
- Fuse Problem
- Stepper Overcurrent

Warnings:

- Charger Warning
- Charger Missing AC
- Low Battery
- Battery Problem
- Exercise Set Error
- USB Warning
- Download Failure

The control panel contains a display which alerts the operator when a fault condition occurs. The above list is not all inclusive. See [Operation](#) for more information about alarms and control panel operation.

NOTE: A warning will indicate a condition on the generator that should be addressed, but will not shut the generator down. An alarm will shut the generator down to protect the system from any damage. In the event of an alarm, an owner can clear the alarm and restart the generator prior to contacting an IASD. If the intermittent issue occurs again, contact an IASD.

Emission Information

The United States Environmental Protection Agency (US EPA) (and California Air Resources Board (CARB), for engines/equipment certified to California standards) requires that this engine/equipment complies with exhaust and evaporative emissions standards. Locate the emissions compliance decal on the engine to determine applicable standards. For emissions warranty information, please reference the included emissions warranty. Follow the maintenance specifications in [Maintenance](#) to ensure that the engine complies with the applicable emissions standards for the duration of the product's life.

This generator is certified to operate on Liquid Propane Vapor fuel or pipeline Natural Gas.

The Emission Control System code is EM (Engine Modification). The Emission Control System on this generator consists of the following:

System	Components
Air Induction	- Intake Manifold - Air Cleaner
Fuel Metering	- Carburetor and Mixer Assembly - Fuel Regulator
Ignition	- Spark Plug - Ignition Module
Exhaust	- Exhaust Manifold - Muffler

Fuel Requirements



DANGER

Explosion and Fire. Fuel and vapors are extremely flammable and explosive. Add fuel in a well ventilated area. Keep fire and spark away. Failure to do so will result in death or serious injury. (000105)

The engine has been fitted with a dual fuel carburetion system. The unit will run on natural gas or LP gas (vapor), but it has been factory set to run on natural gas. The fuel system will be configured for the available fuel source during installation.

Recommended fuels should have a BTU content of at least 1000 BTUs per cubic foot (37.26 megajoules per cubic meter) for natural gas, or at least 2500 BTUs per cubic foot (93.15 megajoules per cubic meter) for LP gas (vapor).

NOTE: If converting to LP gas from natural gas, a minimum LP tank size of 250 gal (946 L) is recommended. See the installation manual for complete procedures and details.

Battery Requirements

12 volts, Group 26R-540CCA minimum or Group 35AGM-650CCA minimum (not included with unit.) See [Maintenance](#) for proper battery maintenance procedures.

Battery Charger

The battery charger is integrated into the control panel module in all models. It operates as a smart charger, which ensures output charging levels are safe and continuously optimized to promote maximum battery life.

Engine Oil Requirements

See [Engine Oil Requirements](#) in the Maintenance section for proper oil viscosity.

Activating the Generator

The generator should be activated upon initial start-up. See the installation manual for complete instructions.

Replacement Parts

Description	9 kW	11 kW	16 kW	20 kW	22 kW
26R Exide Battery	0H3421S				
Spark Plug	0G0767B (RC12YC or equivalent)	0E9368 (RL87YC or equivalent)	0G0767A (RC12YC or equivalent)		
Oil Filter	070185E				
Air Filter	0E9371A		0J8478		
Control Panel Fuse	0D7178T				
Transfer Switch Fuses	073590A				

Accessories

NOTE: Performance enhancing accessories are available for air-cooled generators. Contact an IASD or visit www.generac.com for additional information on replacement parts, accessories, and extended warranties. See also <http://www.ordertree.com/generac/air-cooled-homestandby-generators/>.

Accessory	Description
Cold Weather Accessories*— <ul style="list-style-type: none"> • Battery Pad Warmer • Oil Warmer • Breather Warmer <i>* each sold separately</i>	<ul style="list-style-type: none"> • Recommended in areas where temperatures fall below 0 °F (-18 °C). <i>(Not necessary for use with AGM-style batteries)</i> • Recommended in areas where temperatures fall below 0 °F (-18 °C). • Recommended in areas where heavy icing occurs.
Scheduled Maintenance Kit	Includes all pieces necessary to perform maintenance on the generator along with oil recommendations.
Auxiliary Transfer Switch Lockout	Enables any of the transfer switches to completely lock out one large electrical load by tying into its control system.
Fascia Base Wrap	The fascia base wrap snaps together around the bottom of the new air-cooled generators. This offers a sleek, contoured appearance as well as offering protection from rodents and insects by covering the lifting holes located in the base. Requires use of the mounting pad shipped with the generator.
Mobile Link™ (USA only)	Provides a personalized web portal that displays the generator status, maintenance schedule, event history, and much more. This portal is accessible via computer, tablet, or smart phone. Sends emails and/or text notifications the moment there is any change in the generator's status. Notification settings can be customized to what type of alert is sent and how often. Visit www.MobileLinkGen.com for more information.
Touch-Up Paint Kit	Very important to maintain the look and integrity of the generator enclosure. This kit includes touch-up paint and instructions.
Wireless Local Monitor	The Wireless Local Monitor is completely wireless and battery powered, and provides owners with instant generator status updates without ever leaving the house. Status lights (red, yellow, and green) alert owners when the generator needs attention. Magnetic backing permits refrigerator mounting and gives a 600 ft (183 m) line of sight communication.
Extended Warranty Coverage	Extend your generator warranty coverage by purchasing extended warranty coverage. Covers both parts and labor. Extended coverage can be purchased within 12 months of the end-users purchase date. This extended coverage is applicable to registered units and end-user proof of purchase must be available upon request. Available for Generac® and Guardian® products. Not available for PowerPact™ and EcoGen™ products or all international purchases.

This page intentionally left blank.

Section 3: Operation

Site Prep Verification

The generator must be installed so that airflow into and out of the generator is not impeded. Verify that all shrubs or tall grasses within 3 ft (0.91 m) of the intake and discharge louvers on the sides of the enclosure have been removed. Install the generator on high ground where water levels will not rise and endanger it. This unit should not operate in or be subjected to standing water. Verify that all potential water sources such as water sprinklers, roof run-off, rain gutter downspouts, and sump pump discharges are directed away from the generator enclosure.

⚠ DANGER

Automatic start-up. Disconnect utility power and render unit inoperable before working on unit. Failure to do so will result in death or serious injury.

(000191)

Generator Enclosure

The lid will be locked. A set of keys is attached to the intake side of the generator.

1. Cut the plastic bag to remove the keys.
2. Use the keys to open the lid of the generator.

NOTE: The enclosed keys provided with this unit are intended for service personnel use only.

Opening the Lid

Two locks secure the lid—one on each side (A in [Figure 3-1](#)). Open the protective rubber cap to access the keyhole, and press down on the lid above the side lock and unlock the latch to properly open the lid.

Repeat for the other side. The lid may appear stuck if pressure is not applied from the top.

NOTE: Always verify that the side locks are unlocked before attempting to lift the lid.

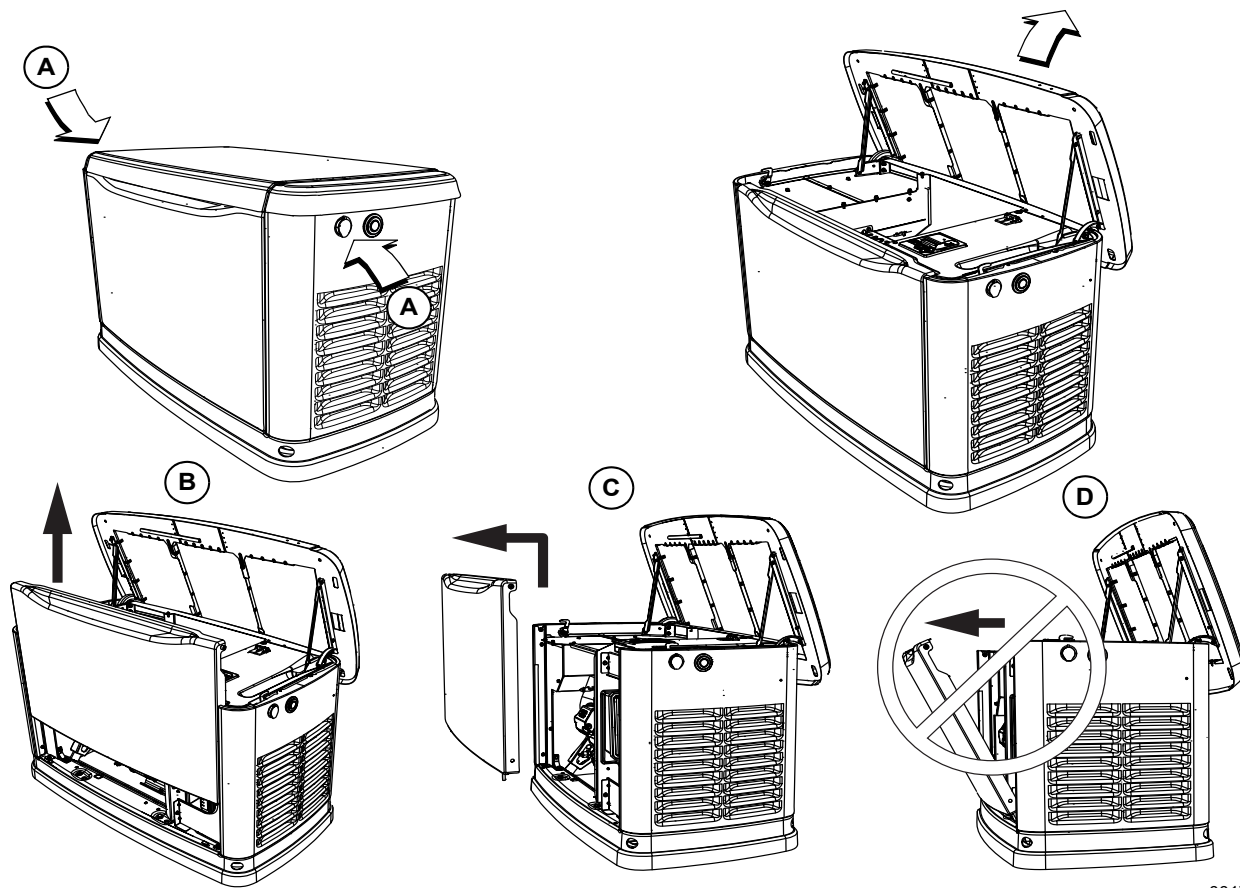

001797

Figure 3-1. Side Lock Location and Front Panel Removal

Intake Side Panel Removal

See **Figure 3-2**. The intake side panel (A) must be removed to access the battery compartment, fuel regulator, and sediment trap.

1. Raise the lid and remove the front panel.
2. Use an Allen wrench to remove two mounting screws (B) and the L-bracket screw (C).

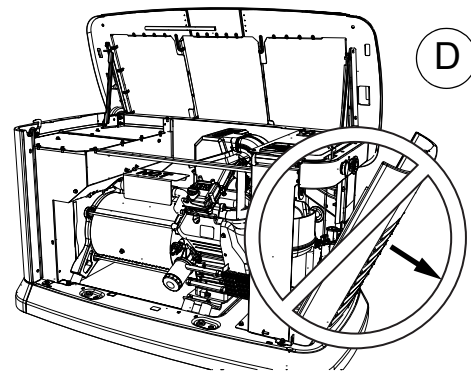
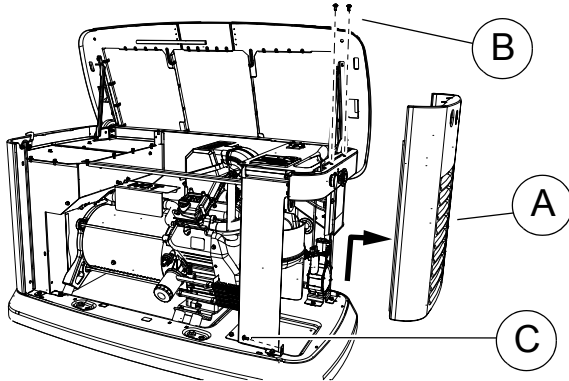

002961

Figure 3-2. Intake Side Panel Removal

Main Line Circuit Breaker (Generator Disconnect)

This is a 2-pole breaker rated according to relevant specifications. See “A” in **Figure 3-3**.

The breaker can be locked in the OFF (OPEN) position for security. Use an appropriately-sized padlock (not included) with a shackle long enough to pass through both lock tabs (B).

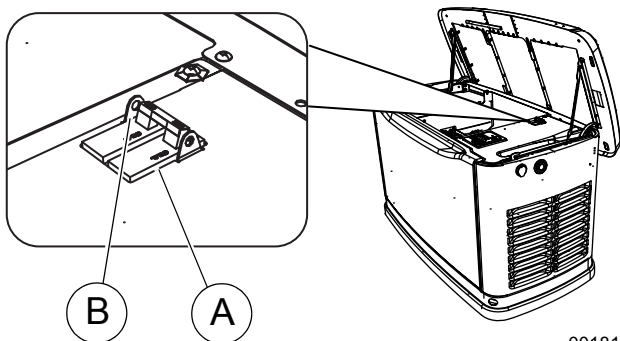

001810

Figure 3-3. Main Breaker

NOTE: DO NOT lock out the MLCB during normal generator operation. Doing so will compromise automatic standby functionality.

LED Indicator Lights

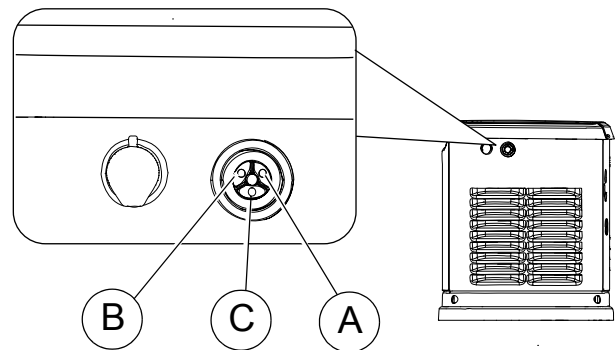

001791

Figure 3-4. LED Indicator Lights

See **Figure 3-4**. Three LEDs are visible behind a translucent lens on the generator side panel. These LEDs indicate the operating status of the generator.

- Green LED “Ready” light (A) is illuminated when utility is present and the control panel button is in the AUTO position. The LED flashes when the automatic transfer switch converts to generator power during a utility power outage.
- Red LED “Alarm” light (B) is illuminated when the generator is OFF or a fault is detected. Contact an IASD.
- Yellow LED “Maintenance” light (C) is illuminated when scheduled maintenance is due.

NOTE: Yellow Maintenance or Warning LED may be on at the same time as either the Red or Green LED.

Control Panel Interface

See [Figure 3-5](#). The control panel interface (A) is located under the lid of the enclosure. Verify that both the left and right side locks are unlocked before attempting to lift the lid of the enclosure. Open the lid as directed in [Opening the Lid](#).

The 7.5A fuse is located beneath the rubber cover (B) to the right of the control panel.

Verify that both the left and right side locks are securely out of the way before closing the unit.

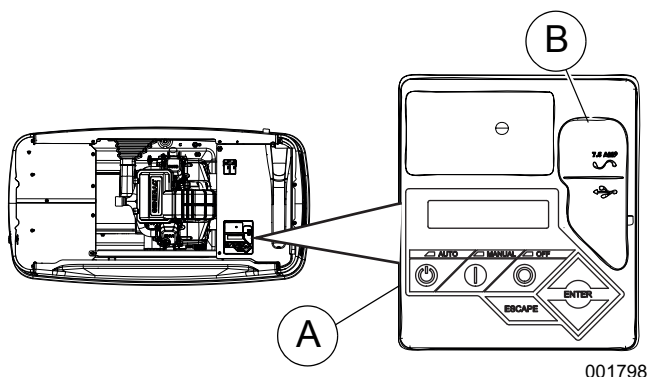

Figure 3-5. Generator Control Panel

All appropriate panels must be in place during any operation of the generator. This includes operation by a servicing technician while conducting troubleshooting procedures.

Using the AUTO/OFF/MANUAL Interface

Button	Description of Operation
AUTO	This button activates fully automatic system operation. It allows the unit to automatically start and exercise the generator according to the exercise timer (see Setting the Exercise Timer). The Green LED on this button will flash if running in Automatic mode and the connected loads are running under generator power (utility is lost).
OFF	This button shuts down the engine and prevents automatic operation of the unit.
MANUAL	This button cranks and starts the generator. Transfer to standby power will not occur unless there is a utility failure. The blue LED on this button will flash if running in manual mode and the connected loads are running under generator power (utility is lost).

NOTE: Damage caused by mis-wiring of the interconnect wires is not warrantable.

Interface Menu Displays

The LCD Panel

Feature	Description
HOME page	Default page that is displayed if no buttons are pressed for 60 seconds. Normally shows current status message and the current date and time. The highest priority active alarm/warning is automatically posted on this page, as well as flashing the backlight when such a condition is detected. In the case of multiple alarms/warnings, only the first message will be displayed. Press the OFF button and then press the ENTER button to clear an alarm or warning.
Display Backlight	Normally off. The backlight will automatically light and remain on for 30 seconds if the operator presses any button.
MAIN MENU page	Allows the operator to navigate to all other pages or sub-menus by using the arrow keys and the ENTER button. Page can be accessed at any time with several presses of the dedicated ESCAPE button. Each press of the ESCAPE button takes the operator to the previous menu until the MAIN MENU displays. This page contains information for - History; Status; Edit; Debug.

Menu System Navigation

To get to the MENU, use the ESCAPE button from any page. You may need to press the ESCAPE button several times before reaching the MENU page. Navigate to the desired menu by using the ↑/↓ buttons. When the desired menu is displayed and flashing, press the ENTER button.

EVOLUTION/SYNC2.0 HSB MENU MAP

Note: Menu functions and features may vary depending on unit model and firmware revision.

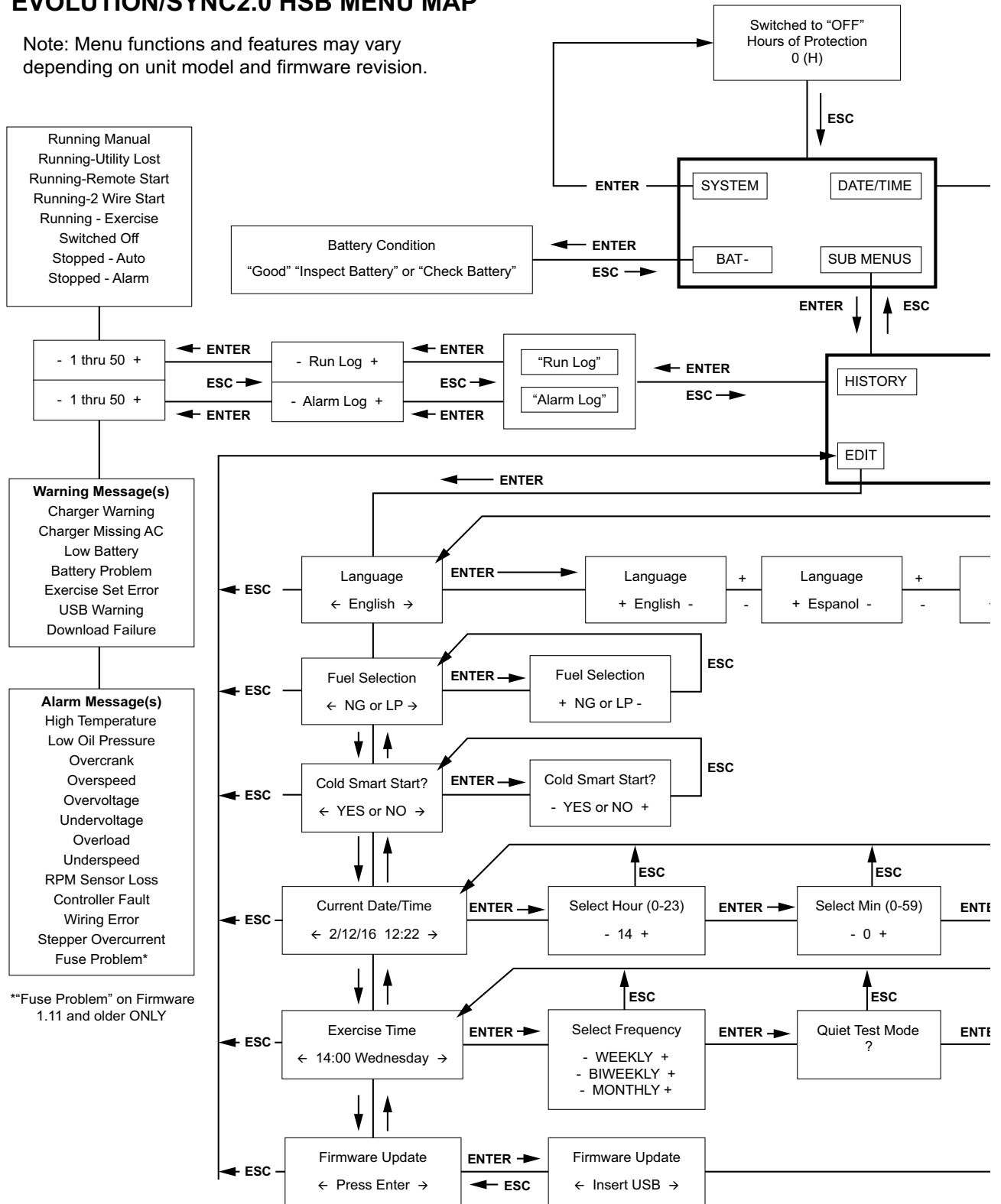

Figure 3-6. Navigation Menu

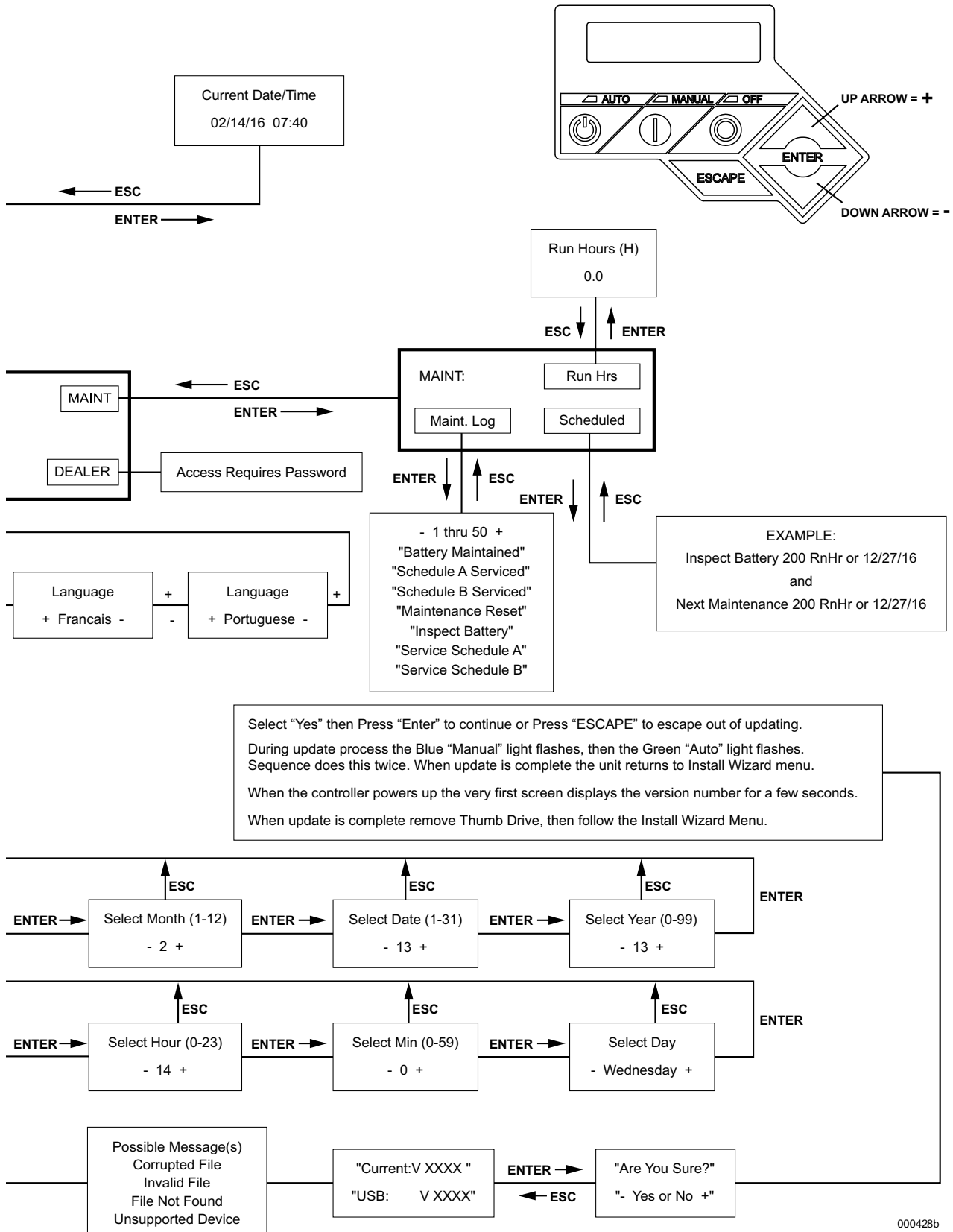

Figure 3-7. Navigation Menu

Setting the Exercise Timer

This generator is equipped with a configurable exercise timer. Configuration can be performed directly at the control panel or through the Mobile Link™ application. There are two settings for the exercise timer:

Day/Time: The generator will start and exercise for the period defined, on the day of the week and at the time of day specified. During this exercise period, the unit runs for approximately five or 12 minutes, depending on the model, and then shuts down.

NOTE: The exercise timer does not automatically adjust for Daylight Savings Time.

Exercise frequency: Exercise frequency can be set to Weekly, Biweekly, or Monthly. If Monthly is selected, the day of the month must be selected from 1-28. The generator will exercise on that day each month. Transfer of loads to the generator output does not occur during the exercise cycle unless utility power is lost.

NOTE: If the installer tests the generator prior to installation, press the ENTER button to skip setting up the exercise timer.

NOTE: The exercise feature will operate only when the generator is in AUTO mode, and will not work unless this procedure is performed. The current date/time will need to be reset every time the 12 volt battery is disconnected and then reconnected, and/or when the fuse is removed.

Table 3-1 details the exercise information and programming options for all Home Standby Generators. **Figure 3-8** illustrates the engine speed profile during a typical exercise cycle for 22 kW generators. **Figure 3-9** shows the engine speed profile for 16–20 kW generators. Smaller generators (9–11 kW) exercise at a constant 3600rpm.

The exercise timer must be reset if the 7.5 amp fuse is removed.

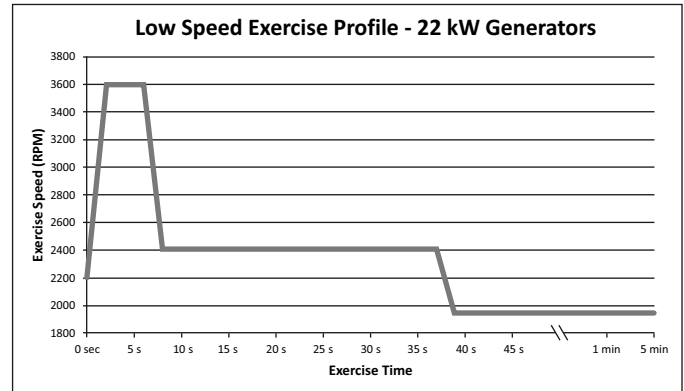

000905

Figure 3-8. Low Speed Exercise Profile (22 kW)

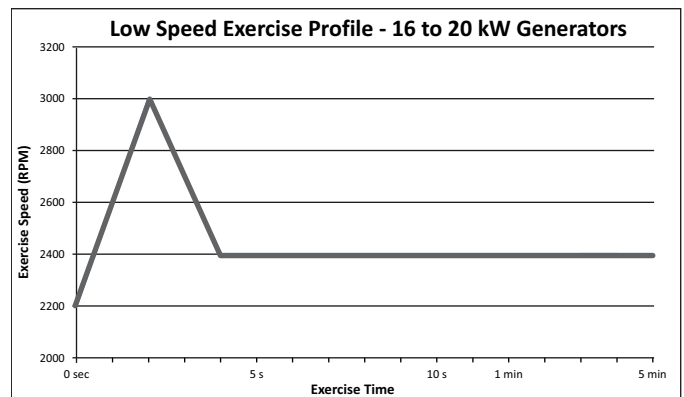

000906

Figure 3-9. Low Speed Exercise Profile (16-20 kW)

Table 3-1. Generator Exercise Characteristics

Generator Size	9 kW	11 kW	16 kW / 20 kW	22 kW
Low Speed Exercise	n/a *	n/a *	2400 rpm	1950 rpm
Exercise Frequency Options	Weekly/Bi-Weekly/Monthly	Weekly/Bi-Weekly/Monthly	Weekly/Bi-Weekly/Monthly	Weekly/Bi-Weekly/Monthly
Exercise Time Length	12 minutes	12 minutes	5 minutes	5 minutes

* exercises at 3600 rpm

Battery Charger

NOTE: The battery charger is integrated into the control module in all models.

The battery charger operates as a smart charger that verifies:

- output is continually optimized to promote maximum battery life.
- charging levels are safe.

NOTE: A warning is displayed on the LCD when the battery needs service.

Manual Transfer Operation



⚠ DANGER

Electrocution. Do not manually transfer under load. Disconnect transfer switch from all power sources prior to manual transfer. Failure to do so will result in death or serious injury, and equipment damage. (000132)

Prior to automatic operation, manually exercise the transfer switch to verify that there is no interference with proper operation of the mechanism. Manual operation of the transfer switch is required if electronic operation should fail.

Transfer to Generator Power Source

1. Verify generator is OFF.
2. Set the main line circuit breaker (MLCB) (generator disconnect) to OFF (OPEN).
3. Turn off the utility power supply to the transfer switch using the means provided (such as a main line utility breaker).
4. Use the manual transfer handle (A in [Figure 3-10](#)) inside the transfer switch to move the main contacts to STANDBY (loads connected to the standby power source).
5. Press the control panel MANUAL button to crank and start the engine.
6. Allow the engine to stabilize and warm up for a few minutes.

7. Set the MLCB (generator disconnect) to ON (CLOSED). The standby power source now powers the loads.

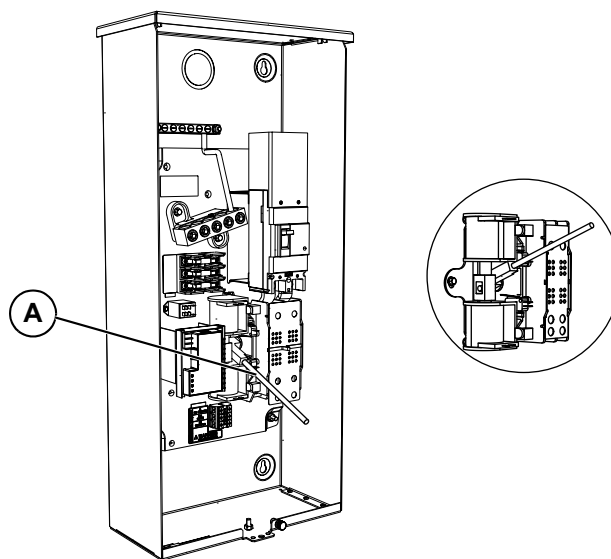

002565

Figure 3-10. Manual Transfer Switch Operation

MANUAL	<ul style="list-style-type: none"> • Will not transfer to generator if utility is present. • Will transfer to generator if utility fails (below 65% of nominal for five consecutive seconds) after warm-up. • Will transfer back when utility returns for 15 consecutive seconds. The engine will continue to run until removed from the MANUAL mode.
AUTO	<ul style="list-style-type: none"> • Will start and run if utility fails for five consecutive seconds (factory default). • Will start an engine warm-up timer (duration varies when Cold Smart Start is enabled). <ul style="list-style-type: none"> –Will not transfer if utility subsequently returns. –Will transfer to generator if utility is not present. • Will transfer to utility once utility returns (above 80% of nominal) for 15 seconds. • Will not transfer to utility unless utility returns. The generator will shut down if the OFF button is pressed or a shutdown alarm is present. • Once utility power is returned, the generator will shut down after one minute cool-down time.
EXERCISE	<ul style="list-style-type: none"> • Will not exercise if generator is already running in either AUTO or MANUAL mode. • During exercise, the controller will only transfer if utility fails during exercise for 10 seconds, and will switch to AUTO.

Transfer to Utility Power Source

When utility power has been restored, transfer to utility source and shut down the generator. Proceed as follows to manually transfer to utility power and shut down the generator:

1. Set the MLCB (generator disconnect) to OFF (OPEN).
2. Run engine for two minutes at no-load to stabilize the internal temperature.
3. Press the control panel OFF button. The engine will shut down.
4. Verify that utility power supply to the transfer switch is turned off.
5. Move the main contacts to the UTILITY position (loads connected to the utility power source) using the manual transfer handle (A in [Figure 3-10](#)) inside the transfer switch.
6. Turn on the utility power supply to the transfer switch using the means provided.
7. Press the control panel AUTO button.
8. Return the MLCB (generator disconnect) to ON (CLOSED).

Automatic Transfer Operation

Proceed as follows to select automatic operation:

1. Verify that the transfer switch main contacts are set to UTILITY (loads connected to the utility power source).
2. Verify that normal utility power source voltage is available to transfer switch terminal lugs N1 and N2.
3. Press the AUTO button on the control panel interface.
4. Set the MLCB (generator disconnect) to ON (CLOSED).

The generator will start automatically when utility source voltage drops below a preset level. Loads are transferred to the standby power source after the unit starts.

Automatic Sequence of Operation

Utility Failure

If the generator is set to AUTO, when utility fails (below 65% of nominal) a 5 second (dealer programmable) line interrupt delay time is started. The engine cranks and starts if the utility is still gone when the timer expires. An engine warm-up timer will be initiated once started. Timer duration varies depending on whether or not Cold Smart Start is enabled. The controller will transfer the load to the generator when the warm-up time expires. If the utility power is restored (above 80% nominal) at any time from the initiation of the engine start until the generator is ready to accept load (warm-up time has not elapsed), the controller completes the start cycle and runs the generator through its normal cool down cycle. However, the load will remain on the utility source.

Cranking

The system will control the cyclic cranking as follows:

- **9 kW Unit:** five cranking cycles as follows: 15 seconds cranking, 7 seconds resting, followed by four additional cycles of 7 seconds cranking followed by 7 seconds resting.
- **11–22 kW Units:** five cranking cycles as follows: 16 seconds cranking, 7 seconds resting, 16 seconds cranking, 7 seconds resting, followed by three additional cycles of 7 seconds cranking followed by 7 seconds resting.

Cold Smart Start

The Cold Smart Start feature is enabled at the factory, but can be disabled in the EDIT menu. The generator will monitor ambient temperature when Cold Smart Start is enabled. The warm-up delay will be adjusted based on prevailing conditions.

If the ambient temperature is below a fixed temperature (based on model) upon startup in AUTO mode, the generator will warm up for 30 seconds. This allows the engine to warm before a load is applied. The generator will startup with the normal warm-up delay of 5 seconds if the ambient temperature is at or above the fixed temperature.

A check for proper output voltage build up will be performed when the generator engine is started.

If some condition impedes normal voltage creation, such as frost crystals or dust/dirt preventing a good electrical connection, the start sequence will be interrupted so that a cleaning cycle of the internal electrical connections can be attempted.

The cleaning cycle is an extended warming up period which lasts for several minutes while the normal generator voltage output is determined to be low. During this cycle, the generator controller will display "Warming Up" on the display screen.

The generator controller display will show "Under Voltage" if the cleaning cycle fails to clear the obstruction. After several minutes, the alarm message can be cleared, and the generator restarted.

If the problem persists, make no further attempts to start. Contact an IASD.

Load Transfer

The transfer of load when the generator is running is dependent upon the operating mode.

Shutting Generator Down While Under Load Or During An Extended Outage

Proceed as follows to turn the generator off during utility outages to perform maintenance or conserve fuel:

To turn the generator OFF (while running in AUTO and online):

1. Turn the main utility disconnect off.
2. Turn the MLCB (generator disconnect) on the generator to OFF (OPEN).
3. Allow generator to run approximately 1 minute for proper cooling.
4. Press the OFF button on the controller.

To turn the generator back ON:

1. Put the generator into AUTO and allow to start and warm-up for a few minutes.
2. Set the MLCB (generator disconnect) on the generator to ON (CLOSED).

The system is now in automatic mode. The main utility disconnect can be turned ON (CLOSED). To shut the unit off, this complete process must be repeated.

This page intentionally left blank.

Section 4: Maintenance

Maintenance

Regular maintenance will improve performance and extend engine/equipment life. Generac Power Systems, Inc. recommends that all maintenance work be performed by an Independent Authorized Service Dealer (IASD). Regular maintenance, replacement, or repair of the emissions control devices and systems may be performed by any repair shop or person of the owner's choosing. To obtain emissions control warranty service free of charge, the work must be performed by an IASD. See the emissions warranty.

WARNING

Only qualified service personnel may install, operate and maintain this equipment. Failure to follow proper installation requirements could result in death, serious injury, and damage to equipment or property. (000182)

Preparing for Maintenance

DANGER

Automatic start-up. Disconnect utility power and render unit inoperable before working on unit. Failure to do so will result in death or serious injury. (000191)

Before performing any maintenance, proceed as follows to prevent the generator from accidental startup:

1. Turn the generator off and allow the engine to cool. Verify that the unit is OFF.
2. With the generator shut down, lift the lid and remove the front panel.
3. Remove the 7.5 amp fuse from the control panel.
4. Remove the intake side panel. (See [Intake Side Panel Removal](#).)
5. See [Figure 4-1](#). Disconnect the white battery charger cable.

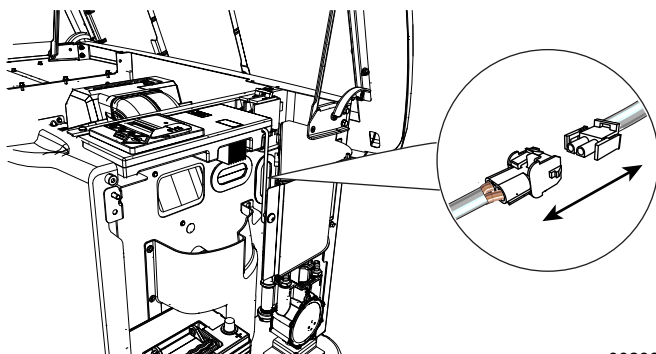

002389

Figure 4-1. Disconnecting Battery Charger Cable

Performing Scheduled Maintenance

It is important to perform maintenance as specified in the [Service Schedule](#) for proper generator operation. Engine oil and oil filter must be changed, and valve clearance adjusted after the first 25 hours of operation.

Emissions-critical maintenance must be performed as scheduled in order for the emissions warranty to be valid. Emissions-critical maintenance consists of servicing the air filter and spark plugs in accordance with the [Service Schedule](#).

The controller will prompt for Schedule A or Schedule B maintenance to be performed. Schedule A maintenance consists of the oil, oil filter, and battery check. Schedule B maintenance includes the oil, oil filter, battery check, air cleaner, spark plug(s), and valve clearance.

Since most maintenance alerts will occur at the same time (most have two year intervals), only one will appear on the control panel display at a time. Once the first alert is cleared, the next active alert will be displayed.

Service Schedule

Service	Daily If Running Continuously or Before Each Use	Every Year	Schedule A Every Two Years or 200 Hours	Schedule B Every Four Years or 400 Hours
Check enclosure louvers for dirt and debris *	•			
Check lines and connections for fuel or oil leaks	•			
Check engine oil level	•			
Check for water intrusion **		•		
Check battery condition, electrolyte level, and state of charge		•	•	•
Replace engine oil and oil filter †			•	•
Replace engine air filter				•
Clean; Check gap; Replace spark plugs				•
Inspect/adjust valve clearance ‡				•
Inspect/clean sediment trap	<i>Consult local codes and guidelines.</i>			
<p>Contact the nearest IASD for assistance if necessary.</p> <p>* Remove any shrubs or tall grasses which have grown within 3 ft (0.91 m) of the intake and discharge louvers on the sides of the enclosure. Clean any debris (dirt, grass clippings, etc.) which have accumulated inside the enclosure.</p> <p>** Verify that all sources of potential water intrusion such as water sprinklers, roof run-off, rain gutter down spouts, and sump pump discharges are directed away from the generator enclosure.</p> <p>† Change engine oil and filter after the first 25 hours of operation. In cold weather conditions (ambient below 40 °F / 4.4 °C), or if unit is operated continuously in hot weather conditions (ambient above 85 °F / 29.4 °C), change engine oil and filter every year or 100 hours of operation.</p> <p>‡ Check/adjust valve clearance after the first 25 hours of operation.</p>				

NOTE: Contact an IASD or visit www.generac.com for additional information on replacement parts.

Maintenance Log

Battery inspection and charge check

Dates Performed:

Oil, oil filter, air filter, and spark plug replacement

Dates Performed:

Valve Adjustment

Dates Performed:

Checking Engine Oil Level



⚠ WARNING

Risk of burns. Allow engine to cool before draining oil or coolant. Failure to do so could result in death or serious injury.

(000139)

⚠ WARNING

Skin irritation. Avoid prolonged or repeated contact with used motor oil. Used motor oil has been shown to cause skin cancer in laboratory animals. Thoroughly wash exposed areas with soap and water.

(000210)

⚠ CAUTION

Engine damage. Verify proper type and quantity of engine oil prior to starting engine. Failure to do so could result in engine damage.

(000135)

The oil level should be checked daily when power outages necessitate running the generator for extended periods. Proceed as follows to check the engine oil level:

1. Run the generator for a cool-down period of approximately one minute.
2. Turn the main utility disconnect off.
3. Turn the main line circuit breaker (MLCB) (generator disconnect) on the generator to OFF (OPEN).
4. Turn the generator off.
5. Press the control panel OFF button. Wait five minutes.
6. Remove the oil dipstick and wipe it dry with a clean cloth.
7. Completely insert the oil dipstick into the oil dipstick tube and remove it.
8. Observe the oil level. The level should be at the "FULL" mark on the oil dipstick.
9. If necessary, remove the oil fill cap and add oil to the engine (with the oil dipstick removed) until the level reaches the "FULL" mark and insert the oil dipstick and fill cap.

To restart the generator:

1. Press the control panel AUTO button.
2. Allow the generator to start and warm up for a few minutes.
3. Set the generator disconnect on the generator to ON (CLOSED).
4. The system is now operating in automatic mode. The main utility disconnect can be turned ON (CLOSED).

Engine Oil Requirements

To maintain the product warranty, the engine oil should be serviced in accordance with the recommendations of this manual. For your convenience, Generac Maintenance Kits are available that include engine oil, oil filter, air filter, spark plug(s), a shop towel, and a funnel. These kits can be obtained from an IASD.

All Generac oil kits meet minimum American Petroleum Institute (API) Service Class SJ, SL, or better. Do not use special additives.

Required Oil—

Synthetic SAE 5W-30 for all temperature ranges.

⚠ CAUTION

Engine damage. Verify proper type and quantity of engine oil prior to starting engine. Failure to do so could result in engine damage.

(000135)

Changing the Oil and Oil Filter

Proceed as follows to change the oil and oil filter:

1. Press the MANUAL button on the control panel to start the engine, and run it until it is thoroughly warmed up. Press the control panel OFF button to shut down the engine.
2. See [Figure 4-2](#) or [Figure 4-3](#). A few minutes after the engine stops, and when it has cooled slightly, lift the lid and remove the front panel. Pull the oil drain hose (A) free of its retaining clip. Remove the cap from the hose and drain the oil into a suitable container.

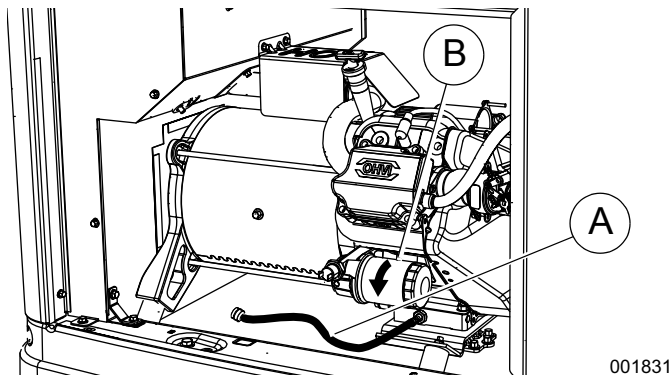

Figure 4-2. Oil Filter and Drain Location (9 kW)

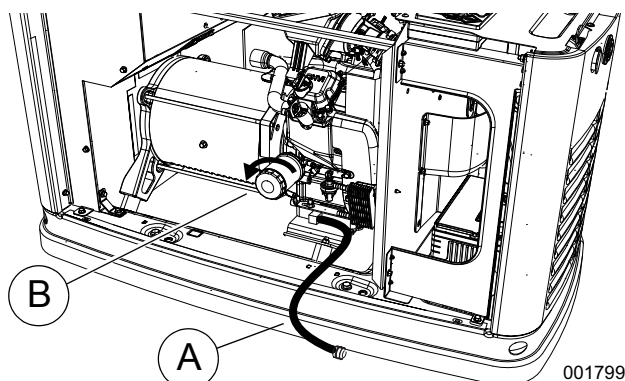

Figure 4-3. Oil Filter and Drain Location (11-22 kW)

3. Replace the cap after the oil has drained. Reposition and secure the hose with the retaining clip.
4. Remove the old oil filter (B) by turning it counterclockwise.
5. Apply a light coating of clean engine oil to the gasket of the new filter.
6. Screw the new filter on by hand until its gasket lightly contacts the oil filter adapter. Tighten the filter an additional 3/4 to one full turn.
7. Refill the engine with the proper recommended oil. See [Engine Oil Requirements](#).

8. Press the MANUAL button on the control panel to start the engine, run for one minute, and check for leaks.
9. Press the OFF button on the control panel to stop the engine. Wait five minutes.
10. Recheck the oil level. Add oil as needed. **DO NOT OVERFILL.**
11. Reinsert oil dipstick and/or reattach fill cap.
12. To return the unit to AUTO mode, press the control panel AUTO button.
13. Dispose of the used oil and filter at a proper collection center.

Servicing the Air Cleaner

Proceed as follows to service the air cleaner:

1. Press the OFF button on the control panel to stop the generator. Then lift the lid and remove the front panel.
2. See [Figure 4-4](#) or [Figure 4-5](#). Remove the cover clips (A) and air cleaner cover (B).

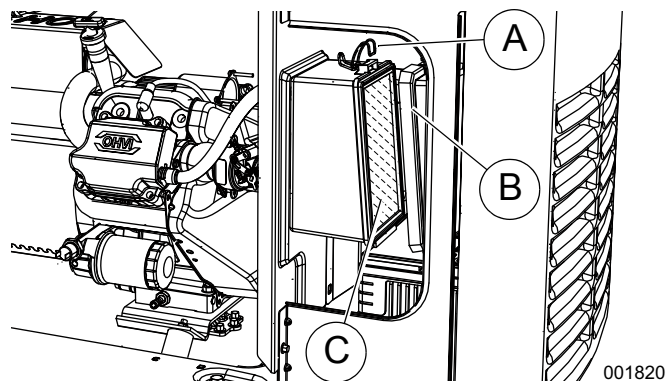

Figure 4-4. Servicing Air Cleaner (9 kW)

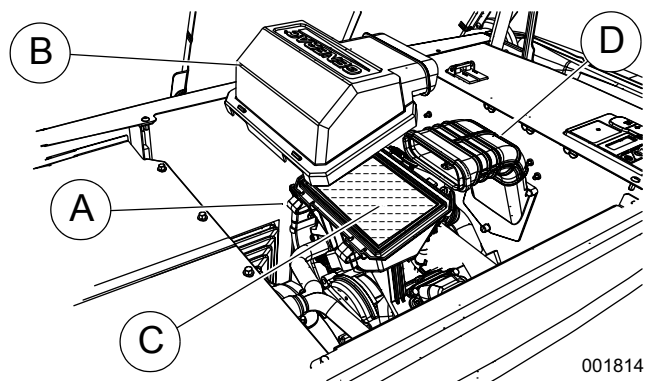

Figure 4-5. Servicing Air Cleaner (11-22 kW)

3. Remove the old air filter element (C) and discard.
4. Thoroughly clean the air cleaner enclosure of any dust or debris.
5. Install a new air filter element.
6. Install the air cleaner cover and fasten the cover clips.

Continued on next page.

7. (11-22 kW units only): Verify that the air inlet duct (D) is properly connected to the air cleaner cover.
8. Press the AUTO button on the control panel to return the unit to AUTO mode.

Spark Plugs

Proceed as follows to check the spark plug(s) gap and replace the spark plug(s) as necessary:

1. With the generator OFF and the engine cool, lift the lid and remove the front panel.
2. Clean the area around the base of the spark plug(s) to keep dirt and debris out of the engine.
3. Remove the spark plug(s) and check the condition. Install a new plug(s) if the old plug(s) is worn or if reuse is questionable.
4. Clean the plug(s) by scraping or washing with a wire brush and commercial solvent. Do not blast the plug(s) to clean.
5. Check the spark plug gap using a wire feeler gauge. See [Figure 4-6](#). Replace the spark plug if the gap is out of specification. See [General Information](#).
6. Reinstall the spark plug(s), and torque to 18.4 ft-lbs (25 Nm).
7. Press the control panel AUTO button to return the unit to AUTO mode.

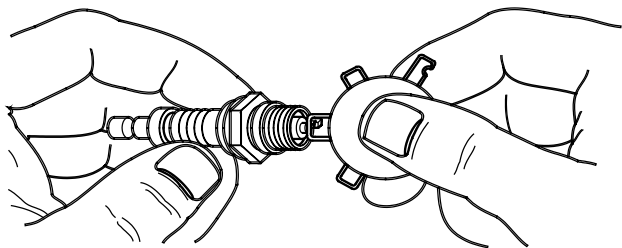

000211

Figure 4-6. Spark Plug Gap Measurement

Valve Clearance Adjustment

Check the valve clearance after the first 25 hours of operation, then after 400 hour intervals. Adjust if necessary.

Important: Please contact an IASD for service assistance. Proper valve clearance is essential for prolonging the life of the engine.

Check Valve Clearance

NOTE: The engine should be cool before checking the valve clearance. Adjustment is not needed if valve clearance is within the dimensions provided in [Specifications](#).

1. Close fuel valve and disconnect battery to avoid accidental start-up.
2. Remove spark plug wires, and position wires away from plugs.
3. Remove spark plugs.
4. Make sure the piston is at top dead center (TDC) of its compression stroke (both valves closed). To move the piston to TDC, remove the intake screen at the front of the engine to access the flywheel nut. Use a large socket and socket wrench to rotate the flywheel nut clockwise, which will rotate the crankshaft. Watch the piston through the spark plug hole. The piston should move up and down. The piston is at TDC when it is at its highest point of travel.

Adjust Valve Clearance

See [Figure 4-7](#) or [Figure 4-8](#). Proceed as follows to adjust the valve clearance:

NOTE: Allow engine to cool before adjusting valve clearance.

1. Make sure the piston is at top dead center (TDC) of its compression stroke (both valves closed).
2. Remove spark plug wire(s) and position wire(s) away from plugs.
3. Remove spark plug(s).
4. Remove the four screws attaching the valve cover. Remove and discard gasket.
5. Loosen the rocker jam nut (C) using a 10 mm wrench (9-11 kW units) or 13 mm wrench (16-22 kW units.)

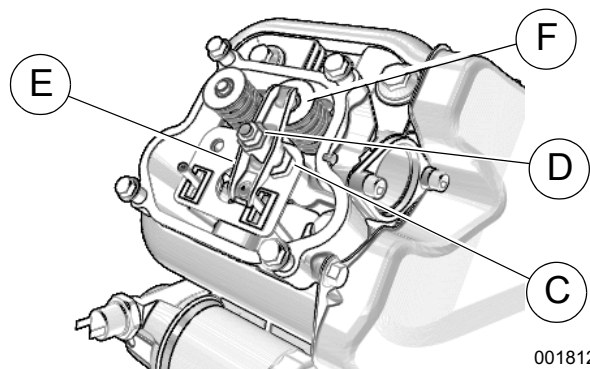

001812

Figure 4-7. Valve Clearance Adjustment (9 kW)

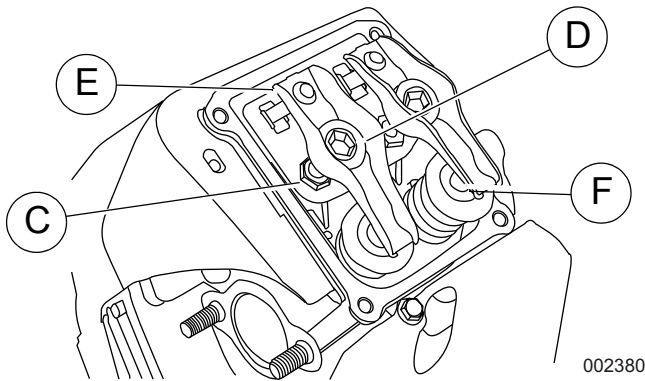

Figure 4-8. Valve Clearance Adjustment (11-22 kW)

6. Turn the pivot ball stud (D) using a 14 mm wrench (9 kW units), 8 mm wrench (11 kW units), or 10 mm Allen wrench (16-22 kW units) while checking clearance between the rocker arm (E) and the valve stem (F) with a feeler gauge. Adjust clearance as per **Specifications**.

NOTE: Hold the rocker arm jam nut in place as the pivot ball stud is turned.

7. When valve clearance is correct, hold the pivot ball stud (B) in place with a wrench and tighten the rocker arm jam nut. Tighten the jam nut according to the following torque specifications:

9 kW	53 in-lbs (6.0 Nm)
11 kW	72 in-lbs (8.2 Nm)
16–22kW	174 in-lbs (19.68 Nm)

8. After tightening the jam nut, recheck valve clearance to verify it did not change.
9. Install new valve cover gasket.
10. Install the valve cover. Tighten fasteners in a cross pattern, torquing to:

9 kW	80 in-lbs (9.0 Nm)
11–22kW	60 in-lbs (6.8 Nm)

NOTE: Start all four screws before tightening, or it will not be possible to get all the screws in place. Verify the valve cover gasket is in place.

11. Install spark plugs and torque to 18 ft-lbs (25 Nm).
12. Reattach the spark plug wire to the spark plug.
13. Repeat the process for the other cylinder if necessary.

Battery Maintenance

The battery should be regularly inspected per the **Service Schedule**. Contact an IASD for assistance if necessary.

Proceed as follows to inspect the battery:

1. Press the OFF button to shut down the generator, then lift the lid and remove the front panel.
2. Remove the 7.5 amp fuse from the control panel.
3. Remove the intake side panel. (See **Intake Side Panel Removal**.)
4. See **Figure 4-1**. Disconnect the white battery charger cable.
5. See **Figure 4-9**. Inspect the battery posts and cables for tightness and corrosion. Tighten and clean as necessary.

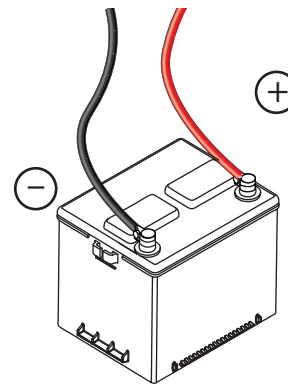

Figure 4-9. Battery Cables

6. (Unsealed batteries only): Completely disconnect the battery. Check the battery fluid level and, if necessary, fill with distilled water only. **DO NOT** use tap water. Also, have an IASD or a qualified service technician check the state of charge and condition.
7. When inspection is complete, reconnect the battery cables, the battery charger cable, reinstall the intake side panel, and reinstall the 7.5 amp fuse.
8. Reinstall the front panel and close the generator lid.
9. Place the controller in AUTO mode.

WARNING



Explosion. Do not dispose of batteries in a fire. Batteries are explosive. Electrolyte solution can cause burns and blindness. If electrolyte contacts skin or eyes, flush with water and seek immediate medical attention. (000162)

WARNING



Explosion. Batteries emit explosive gases while charging. Keep fire and spark away. Wear protective gear when working with batteries. Failure to do so could result in death or serious injury. (000137a)

**WARNING**

Electrical shock. Disconnect battery ground terminal before working on battery or battery wires. Failure to do so could result in death or serious injury. (000164)

**WARNING**

Risk of burns. Batteries contain sulfuric acid and can cause severe chemical burns. Wear protective gear when working with batteries. Failure to do so could result in death or serious injury. (000138a)

WARNING

Environmental Hazard. Always recycle batteries at an official recycling center in accordance with all local laws and regulations. Failure to do so could result in environmental damage, death or serious injury. (000228)

Always recycle batteries in accordance with local laws and regulations. Contact your local solid waste collection site or recycling facility to obtain information on local recycling processes. For more information on battery recycling, visit the Battery Council International website at: <http://batteryCouncil.org>.

Strictly observe the following precautions when working on batteries:

- Remove the 7.5 amp fuse from the generator control panel.
- Disconnect the battery charger as directed in [Battery Maintenance](#).
- Remove all jewelry—watches, rings, metal objects, etc.
- Use tools with insulated handles.
- Wear rubber gloves and boots.
- Do not place tools or metallic objects on top of the battery.
- Disconnect the charging source prior to connecting or disconnecting battery terminals.
- Wear full eye protection and protective clothing.
- If electrolyte contacts the skin, wash it off immediately with water.
- If electrolyte contacts the eyes, immediately thoroughly flush with water and seek medical attention.
- Wash down spilled electrolyte with an acid neutralizing agent. A common practice is to use a solution of 1 lb (454 g) bicarbonate of soda to 1 gal (3.8 L) of water. Add bicarbonate of soda solution until the evidence of reaction (foaming) has ceased. Flush the resulting liquid with water and dry the area completely.

- DO NOT smoke when near the battery.
- DO NOT cause flame or spark in the battery area.
- Discharge static electricity from the body before touching the battery by first touching a grounded metal surface.

Cleaning the Sediment Trap

The sediment trap removes contaminants (moisture and fine particles) from gaseous fuels before they enter the fuel regulator. Accumulated moisture and particles must be emptied from the sediment trap per local codes and guidelines.

Proceed as follows to clean the sediment trap:

1. Remove the intake side panel (see [Intake Side Panel Removal](#)).
2. Turn the generator fuel supply off.
3. See [Figure 4-10](#). Unscrew and remove the cap (A).

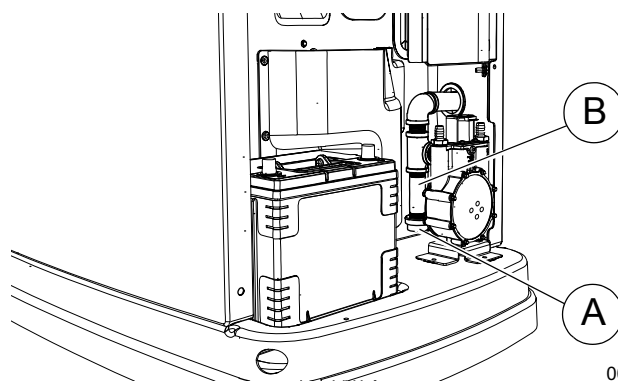

Figure 4-10. Cleaning the Sediment Trap

4. Use a clean-out tool (not provided) to remove accumulated moisture and particles from the cap and body (B).
5. Wipe the inside of each component with a clean, dry, lint-free cloth.
6. Seal the threads of the cap with appropriate sealing compound. Install the cap and hand-tighten.
7. Tighten the cap with an appropriately sized pipe wrench. DO NOT overtighten.
8. Turn the generator fuel supply on. Check for leaks by spraying all connection points with a non-corrosive gas leak detection fluid. The solution should not be blown away or form bubbles.
9. Install the intake side panel.

Attention After Submersion

DO NOT start or operate the generator if it has been submerged in water. Have an IASD thoroughly clean, dry, and inspect the generator following any submersion in water. If the structure (home) has been flooded, it should be inspected by a certified electrician to verify there won't

be any electrical problems during generator operation or when utility power is returned.

Corrosion Protection

Regular scheduled maintenance should be conducted to perform a visual inspection of the unit for corrosion. Inspect all metal components of the generator, including the base frame, brackets, alternator can, the entire fuel system (inside and outside of the generator), and fastener locations. If there is corrosion found on generator components (e.g. regulator, engine/alternator mounts, fuel plenum, etc.), replace parts as necessary.

Periodically wash and wax the enclosure using automotive type products. Do not spray the unit with a hose or power washer. Use warm, soapy water and a soft cloth. Frequent washing is recommended in salt water/coastal areas. Spray engine linkages with a light oil such as WD-40.

Remove From, and Return To Service Procedure

Remove From Service

If the generator cannot be exercised monthly, at a minimum, and will be out of service longer than 90 days, proceed as follows to prepare the generator for storage:

1. Start the engine and let it warm up.
2. Close the fuel shutoff valve in the fuel supply line and allow the engine to stop.
3. Once the engine has stopped, set the generator MLCB (generator disconnect) to OFF (OPEN).
4. Turn off the utility power to the transfer switch.
5. See [Figure 4-1](#). Remove battery charger AC input T1/Neutral cable (has white sleeve) at controller.
6. Remove the 7.5 amp fuse from the generator's control panel.
7. Disconnect the battery cables. Remove the negative cable first.



WARNING

Explosion. Batteries emit explosive gases. Always disconnect negative battery cable first to avoid spark. Failure to do so could result in death or serious injury. (000238)

8. Drain the oil completely while the engine is still warm, and then refill the crankcase with oil.
9. Attach a tag to the engine indicating the viscosity and classification of the new oil in the crankcase.
10. Remove the spark plug(s) and spray a fogging agent into the spark plug(s) threaded openings. Reinstall and tighten the spark plug(s) to specification.

11. Remove the battery and store it in a cool, dry room on a wooden board.
12. Clean and wipe down the entire generator.

Return to Service

Proceed as follows to return the unit to service after storage:

1. Verify utility power is off.
2. Check the tag on the engine for oil viscosity and classification. Drain and refill with proper oil, if necessary.
3. Check the state of the battery. Fill all cells of unsealed batteries to the proper level with distilled water. DO NOT use tap water. Recharge the battery to 100% state of charge. Replace the battery if defective.
4. Clean and wipe down the entire generator.
5. Verify that the 7.5 amp fuse is removed from the generator control panel.
6. Reconnect the battery. Observe battery polarity. Damage may occur if the battery is connected incorrectly. Install positive cable first.
7. Reconnect the battery charger AC input T1/Neutral cable (white sleeve) at controller.
8. Open the fuel shutoff valve.
9. Insert the 7.5 amp fuse into the generator control panel.
10. Press the MANUAL button to start the unit. Allow the unit to warm up for a few minutes.
11. Complete the Installation Wizard information.
12. Press the control panel OFF button to stop the unit.
13. Turn on the utility power to the transfer switch.
14. Set the control panel to AUTO.

The generator is ready for service.

NOTE: The exercise timer and current date and time must be reset when a battery is dead or has been disconnected.

Section 5: Troubleshooting / Quick Reference Guide

Generator Troubleshooting

Problem	Cause	Correction
Engine will not crank.	<ol style="list-style-type: none"> 1. Blown fuse. 2. Loose, corroded, or defective battery cables. 3. Defective starter contact. 4. Defective starter motor. 5. Discharged battery. 	<ol style="list-style-type: none"> 1. Correct short circuit condition by replacing 7.5 amp fuse in generator control panel. Contact an Independent Authorized Service Dealer (IASD) if fuse continues to blow. 2. Tighten, clean, or replace as necessary.* 3. *See #2. 4. *See #2. 5. Charge or replace battery.
Engine cranks but will not start.	<ol style="list-style-type: none"> 1. No fuel. 2. Defective fuel solenoid (FS). 3. Open Wire 14 from controller. 4. Defective spark plug(s). 5. Valve clearance out of adjustment. 	<ol style="list-style-type: none"> 1. Replenish fuel / turn on fuel valve. 2. * 3. * 4. Clean; check gap; replace plug(s) if necessary. 5. Reset valve clearance.
Engine starts hard and runs rough.	<ol style="list-style-type: none"> 1. Air cleaner plugged or damaged. 2. Defective spark plug(s). 3. Incorrect fuel pressure. 4. Fuel selector in wrong position. 5. Valve(s) out of adjustment. 6. Internal engine issue. 	<ol style="list-style-type: none"> 1. Check and clean air cleaner. 2. Clean; check gap; replace plug(s) as needed. 3. Confirm fuel pressure to regulator is 10–12 in water column (19–22 mm Hg) for LP, and 3.5–7.0 in water column (9–13 mm Hg) for natural gas. 4. Turn fuel conversion valve to correct position. 5. Adjust valve clearance. 6. *
Generator is set to OFF, but the engine continues to run.	<ol style="list-style-type: none"> 1. Controller wired incorrectly. 2. Defective control board. 	<ol style="list-style-type: none"> 1. * 2. *
No AC output from generator.	<ol style="list-style-type: none"> 1. Main line circuit breaker (MLCB) (generator disconnect) is OFF (OPEN). 2. Generator internal failure. 3. Engine may be warming up. Refer to Cold Smart Start. 	<ol style="list-style-type: none"> 1. Reset generator disconnect to ON (CLOSED). 2. * 3. Check the controller screen to verify status.
No transfer to standby after utility source failure.	<ol style="list-style-type: none"> 1. MLCB (generator disconnect) is OFF (OPEN). 2. Defective transfer switch coil. 3. Defective transfer relay. 4. Transfer relay circuit open. 5. Defective control logic board. 6. Engine may be warming up. Refer to Cold Smart Start. 	<ol style="list-style-type: none"> 1. Reset generator disconnect to ON (CLOSED). 2. * 3. * 4. * 5. * 6. Check the controller screen to verify status.
Unit consumes large amounts of oil.	<ol style="list-style-type: none"> 1. Excessive engine oil. 2. Defective engine breather. 3. Improper type or viscosity of oil. 4. Damaged gasket, seal, or hose. 5. Restricted air filter. 	<ol style="list-style-type: none"> 1. Adjust oil to proper level. 2. * 3. See Engine Oil Requirements. 4. Check for oil leaks. 5. Replace air filter.
* Contact an IASD for assistance.		

Quick Reference Guide

To clear an active alarm, press the OFF button, the ENTER button, and then press AUTO. If the alarm reoccurs, contact an IASD.

Active Alarm	LED	Problem	Things to Check	Solution
NONE	GREEN	Unit running in AUTO but no power in house.	Check MLCB.	Check MLCB. If it is ON, contact an IASD.
HIGH TEMPERATURE	RED	Unit shuts down during operation.	Check the LEDs / screen for alarms.	Check ventilation around the generator, intake, exhaust, and rear of generator. If no obstructions are present, contact an IASD.
OVERLOAD REMOVE LOAD	RED	Unit shuts down during operation.	Check the LEDs / screen for alarms.	Clear alarm and remove household loads from the generator. Put in AUTO and restart.
RPM SENSE LOSS	RED	Unit was running and shut down, attempts to restart.	Check the LEDs / screen for alarms.	Clear alarm and remove household loads from the generator. Put into AUTO and restart. If generator does not start, contact an IASD.
NOT ACTIVATED	NONE	Unit will not start in AUTO with utility loss.	Check if screen says unit not activated.	Refer to "Activation" in installation manual.
NONE	GREEN	Unit will not start in AUTO with utility loss.	Check screen for start delay countdown.	If the startup delay is greater than expected, contact an IASD to adjust from 2 to 1500 seconds.
LOW OIL PRESSURE	RED	Unit will not start in AUTO with utility loss.	Check the LEDs / screen for alarms.	Check oil level and add oil as needed. If oil level is correct, contact an IASD.
RPM SENSE LOSS	RED	Unit will not start in AUTO with utility loss.	Check the LEDs / screen for alarms.	Clear alarm. Using the control panel, check the battery by navigating to the BATTERY MENU option from the MAIN MENU. If battery condition displays GOOD, contact an IASD. If control panel displays CHECK BATTERY, replace the battery.
OVERCRANK	RED	Unit will not start in AUTO with utility loss.	Check the LEDs / screen for alarms.	Check fuel line shutoff valve is ON. Clear alarm. Start the unit in MANUAL. If it does not start, or starts and runs rough, contact an IASD.
LOW VOLTS REMOVE LOAD	RED	Unit will not start in AUTO with utility loss.	Check the LEDs / screen for alarms.	Clear alarm and remove household loads from the generator. Put in AUTO and restart.
FUSE PROBLEM	RED	Unit will not start in AUTO with utility loss.	Check the LEDs / screen for alarms.	Check the 7.5 amp fuse. If it is blown, replace it with an ATO 7.5 amp fuse. If the fuse is intact, contact an IASD.
OVERSPEED	RED	Unit will not start in AUTO with utility loss.	Check the LEDs / screen for alarms.	Contact an IASD.
UNDERVOLTAGE	RED	Unit will not start in AUTO with utility loss.	Check the LEDs / screen for alarms.	Contact an IASD.
UNDERSPEED	RED	Unit will not start in AUTO with utility loss.	Check the LEDs / screen for alarms.	Contact an IASD.
STEPPER OVERCURRENT	RED	Unit will not start in AUTO with utility loss.	Check the LEDs / screen for alarms.	Contact an IASD.

Active Alarm	LED	Problem	Things to Check	Solution
MISWIRE	RED	Unit will not start in AUTO with utility loss.	Check the LEDs / screen for alarms.	Contact an IASD.
OVERVOLTAGE	RED	Unit will not start in AUTO with utility loss.	Check the LEDs / screen for alarms.	Contact an IASD.
LOW BATTERY	YELLOW	Yellow LED illuminated in any state.	Check the screen for additional information.	Clear alarm. Using the control panel, check the battery by navigating to the BATTERY MENU option from the MAIN MENU. If battery condition displays GOOD, contact an IASD. If control panel displays CHECK BATTERY, replace the battery.
BATTERY PROBLEM	YELLOW	Yellow LED illuminated in any state.	Check the screen for additional information.	Contact an IASD.
CHARGER WARNING	YELLOW	Yellow LED illuminated in any state.	Check the screen for additional information.	Contact an IASD.
SERVICE A	YELLOW	Yellow LED illuminated in any state.	Check the screen for additional information.	Perform SERVICE A maintenance. Press ENTER to clear.
SERVICE B	YELLOW	Yellow LED illuminated in any state.	Check the screen for additional information.	Perform SERVICE B maintenance. Press ENTER to clear.
INSPECT BATTERY	YELLOW	Yellow LED illuminated in any state.	Check the screen for additional information.	Inspect battery. Press ENTER to clear.

This page intentionally left blank.

This page intentionally left blank.

This page intentionally left blank.



Part No. 0L6629 Rev. A 07/12/16
©2016 Generac Power Systems, Inc. All rights reserved
Specifications are subject to change without notice.
No reproduction allowed in any form without prior written
consent from Generac Power Systems, Inc.

Generac Power Systems, Inc.
S45 W29290 Hwy. 59
Waukesha, WI 53189
1-888-GENERAC (1-888-436-3722)
generac.com