

## 16/20/22 kW

### GUARDIAN® SERIES Residential Standby Generators Air-Cooled Gas Engine

#### INCLUDES:

- True Power™ Electrical Technology
- Two-line multilingual digital LCD Evolution™ controller (English/Spanish/French/Portuguese)
- Two transfer switch options available:  
100 amp, 16 circuit switch or  
200 amp service rated smart switch
- Electronic governor
- Standard Wi-Fi™ connectivity available on 16kW and 20kW -1 models and 22kW models
- System status & maintenance interval LED indicators
- Sound attenuated enclosure
- Flexible fuel line connector
- Natural gas or LP gas operation
- 5 Year limited warranty
- Listed and labeled by the Southwest Research Institute allowing installation as close as 18 in (457 mm) to a structure.\*  
*\*Must be located away from doors, windows, and fresh air intakes and in accordance with local codes.*

[https://assets.swri.org/library/DirectoryOfListedProducts/ConstructionIndustry/973\\_DoC\\_204\\_13204-01-01\\_Rev9.pdf](https://assets.swri.org/library/DirectoryOfListedProducts/ConstructionIndustry/973_DoC_204_13204-01-01_Rev9.pdf)

#### Standby Power Rating

G007035-1, G007036-1, G007037-1 (Aluminum - Bisque) - 16 kW 60 Hz  
G007038-1, G007039-1 (Aluminum - Bisque) - 20 kW 60 Hz  
G007042-10, G007043-10 (Aluminum - Bisque) - 22 kW 60 Hz



Product shown with optional fascia kit



Note: CETL or CUL certification only applies to unbundled units and units packaged with limited circuit switches. Units packaged with the Smart Switch are ETL or UL certified in the USA only.

## FEATURES

- **INNOVATIVE ENGINE DESIGN & RIGOROUS TESTING** are at the heart of Generac's success in providing the most reliable generators possible. Generac's G-Force engine lineup offers added peace of mind and reliability for when it's needed the most. The G-Force series engines are purpose built and designed to handle the rigors of extended run times in high temperatures and extreme operating conditions.
- **TRUE POWER™ ELECTRICAL TECHNOLOGY:** Superior harmonics and sine wave form produce less than 5% Total Harmonic Distortion for utility quality power. This allows confident operation of sensitive electronic equipment and micro-chip based appliances, such as variable speed HVAC systems.
- **TEST CRITERIA:**
  - ✓ **PROTOTYPE TESTED**
  - ✓ **SYSTEM TORSIONAL TESTED**
  - ✓ **NEMA MG1-22 EVALUATION**
  - ✓ **MOTOR STARTING ABILITY**
- **MOBILE LINK® CONNECTIVITY:** FREE with select Guardian Series Home standby generators, Mobile Link Wi-Fi allows users to monitor the status of the generator from anywhere in the world using a smartphone, tablet, or PC. Easily access information such as the current operating status and maintenance alerts. Users can connect an account to an authorized service dealer for fast, friendly, and proactive service. With Mobile Link, users are taken care of before the next power outage.
- **SOLID-STATE, FREQUENCY COMPENSATED VOLTAGE REGULATION:** This state-of-the-art power maximizing regulation system is standard on all Generac models. It provides optimized FAST RESPONSE to changing load conditions and MAXIMUM MOTOR STARTING CAPABILITY by electronically torque-matching the surge loads to the engine. Digital voltage regulation at ±1%.
- **SINGLE SOURCE SERVICE RESPONSE** from Generac's extensive dealer network provides parts and service know-how for the entire unit, from the engine to the smallest electronic component.
- **GENERAC TRANSFER SWITCHES:** Long life and reliability are synonymous with GENERAC POWER SYSTEMS. One reason for this confidence is that the GENERAC product line is offered with its own transfer systems and controls for total system compatibility.

## 16/20/22 kW

## Features and Benefits

**Engine**

- Generac G-Force design
- “Spiny-lok” cast iron cylinder walls
- Electronic ignition/spark advance
- Full pressure lubrication system
- Low oil pressure shutdown system
- High temperature shutdown

Maximizes engine “breathing” for increased fuel efficiency. Plateau honed cylinder walls and plasma moly rings help the engine run cooler, reducing oil consumption and resulting in longer engine life.

Rigid construction and added durability provide long engine life.

These features combine to assure smooth, quick starting every time.

Pressurized lubrication to all vital bearings means better performance, less maintenance, and longer engine life. Now featuring up to a 2 year/200 hour oil change interval.

Shutdown protection prevents catastrophic engine damage due to low oil.

Prevents damage due to overheating.

**Generator**

- Revolving field
- Skewed stator
- Displaced phase excitation
- Automatic voltage regulation
- EPA Certified for non-emergency applications
- UL 2200 listed

Allows for a smaller, light weight unit that operates 25% more efficiently than a revolving armature generator.

Produces a smooth output waveform for compatibility with electronic equipment.

Maximizes motor starting capability.

Regulating output voltage to  $\pm 1\%$  prevents damaging voltage spikes.

Allows unit to be used for demand response applications (applicable to 22 kW units).

For your safety.

**Transfer Switch (if applicable)**

- Fully automatic
- NEMA 3R
- Remote mounting

Transfers vital electrical loads to the energized source of power.

Can be installed inside or outside for maximum flexibility.

Mounts near an existing distribution panel for simple, low-cost installation.

**Evolution™ Controls**

- AUTO/MANUAL/OFF illuminated buttons
- Two-line multilingual LCD
- Sealed, raised buttons
- Utility voltage sensing
- Generator voltage sensing
- Utility interrupt delay
- Engine warm-up
- Engine cool-down
- Programmable exercise
- Smart battery charger
- Main line circuit breaker
- Electronic governor

Selects the operating mode and provides easy, at-a-glance status indication in any condition.

Provides homeowners easily visible logs of history, maintenance, and events up to 50 occurrences.

Smooth, weather-resistant user interface for programming and operations.

Constantly monitors utility voltage, setpoints 65% dropout, 80% pick-up, of standard voltage.

Constantly monitors generator voltage to verify the cleanest power delivered to the home.

Prevents nuisance start-ups of the engine, adjustable 2-1500 seconds from the factory default setting of 5 seconds by a qualified dealer.

Verifies engine is ready to assume the load, setpoint approximately 5 seconds.

Allows engine to cool prior to shutdown, setpoint approximately 1 minute.

Operates engine to prevent oil seal drying and damage between power outages by running the generator for 5 minutes every other week. Also offers a selectable setting for weekly or monthly operation providing flexibility and potentially lower fuel costs to the owner.

Delivers charge to the battery only when needed at varying rates depending on outdoor air temperature. Compatible with lead acid and AGM-style batteries.

Protects generator from overload.

Maintains constant 60 Hz frequency.

**Unit**

- SAE weather protective enclosure
- Enclosed critical grade muffler
- Small, compact, attractive

Sound attenuated enclosures ensure quiet operation and protection against mother nature, withstanding winds up to 150 mph (241 km/h). Hinged key locking roof panel for security. Lift-out front for easy access to all routine maintenance items. Electrostatically applied textured epoxy paint for added durability.

Quiet, critical grade muffler is mounted inside the unit to prevent injuries.

Makes for an easy, eye appealing installation, as close as 18 in (457 mm) away from a structure.

**Installation System**

- 14 in (35.6 cm) flexible fuel line connector  
Listed ANSI Z21.75/CSA 6.27 outdoor appliance connector for the required connection to the gas supply piping.
- Integral sediment trap  
Meets IFGC and NFPA 54 installation requirements.

**Connectivity (Wi-Fi equipped models only)**

- Ability to view generator status  
Monitor generator with a smartphone, tablet, or computer at any time via the Mobile Link application for complete peace of mind.
- Ability to view generator Exercise/Run and Total Hours  
Review the generator's complete protection profile for exercise hours and total hours.
- Ability to view generator maintenance information  
Provides maintenance information for the specific model generator when scheduled maintenance is due.
- Monthly report with previous month's activity  
Detailed monthly reports provide historical generator information.
- Ability to view generator battery information  
Built in battery diagnostics displaying current state of the battery.
- Weather information  
Provides detailed local ambient weather conditions for generator location.

## 16/20/22 kW

## Generator

Model	16 kW	20 kW	22 kW
Rated maximum continuous power capacity (LP)	16,000 Watts*	20,000 Watts*	22,000 Watts*
Rated maximum continuous power capacity (NG)	16,000 Watts*	18,000 Watts*	19,500 Watts*
Rated voltage	240	240	240
Rated maximum continuous load current – 240 volts (LP/NG)	66.7 / 66.7	83.3 / 75.0	91.7 / 81.3
Total Harmonic Distortion	Less than 5%		
Main line circuit breaker	70 amp	90 amp	100 amp
Phase	1		
Number of rotor poles	2		
Rated AC frequency	60 Hz		
Power factor	1.0		
Battery requirement (not included)	12 Volts, Group 26R 540 CCA minimum or Group 35AGM 650 CCA minimum		
Unit weight (lb / kg)	409 / 186	448 / 203	466 / 211
Dimensions (L x W x H) in / cm	48 x 25 x 29 / 121.9 x 63.5 x 73.7		
Sound output in dB(A) at 23 ft (7 m) with generator operating at normal load**	67	67	67
Sound output in dB(A) at 23 ft (7 m) with generator in Quiet-Test™ low-speed exercise mode**	55	55	57
Exercise duration	5 min		

## Engine

Engine type	GENERAC G-Force 1000 Series		
Number of cylinders	2		
Displacement	999 cc		
Cylinder block	Aluminum w/ cast iron sleeve		
Valve arrangement	Overhead valve		
Ignition system	Solid-state w/ magneto		
Governor system	Electronic		
Compression ratio	9.5:1		
Starter	12 VDC		
Oil capacity including filter	Approx. 1.9 qt / 1.8 L		
Operating rpm	3,600		
Fuel consumption			
Natural gas	ft <sup>3</sup> /hr (m <sup>3</sup> /hr)		
	1/2 Load	218 (6.17)	204 (5.78)
	Full Load	309 (8.75)	301 (8.52)
Liquid propane	ft <sup>3</sup> /hr (gal/hr) [L/hr]		
	1/2 Load	74 (2.03) [7.70]	87 (2.37) [8.99]
	Full Load	107 (2.94) [11.11]	130 (3.56) [13.48]
			92 (2.53) [9.57]
			142 (3.90) [14.77]

Note: **Fuel pipe must be sized for full load.** Required fuel pressure to generator fuel inlet at all load ranges - 3.5–7 in water column (0.87–1.74 kPa) for NG, 10–12 in water column (2.49–2.99 kPa) for LP gas. For BTU content, multiply ft<sup>3</sup>/hr x 2500 (LP) or ft<sup>3</sup>/hr x 1000 (NG). For Megajoule content, multiply m<sup>3</sup>/hr x 93.15 (LP) or m<sup>3</sup>/hr x 37.26 (NG).

## Controls

Two-line plain text multilingual LCD	Simple user interface for ease of operation.
Mode buttons: AUTO	Automatic start on utility failure. 7 day exerciser.
MANUAL	Start with starter control, unit stays on. If utility fails, transfer to load takes place.
OFF	Stops unit. Power is removed. Control and charger still operate.
Ready to Run/Maintenance messages	Standard
Engine run hours indication	Standard
Programmable start delay between 2–1500 seconds	Standard (programmable by dealer only)
Utility Voltage Loss/Return to Utility adjustable (brownout setting)	From 140–171 V / 190–216 V
Future Set Capable Exerciser/Exercise Set Error warning	Standard
Run/Alarm/Maintenance logs	50 events each
Engine start sequence	Cyclic cranking: 16 sec on, 7 rest (90 sec maximum duration).
Starter lock-out	Starter cannot re-engage until 5 sec after engine has stopped.
Smart Battery Charger	Standard
Charger Fault/Missing AC warning	Standard
Low Battery/Battery Problem Protection and Battery Condition indication	Standard
Automatic Voltage Regulation with Over and Under Voltage Protection	Standard
Under-Frequency/Overload/Stepper Overcurrent Protection	Standard
Safety Fused/Fuse Problem Protection	Standard
Automatic Low Oil Pressure/High Oil Temperature Shutdown	Standard
Overcrank/Overspeed (@ 72 Hz)/rpm Sense Loss Shutdown	Standard
High Engine Temperature Shutdown	Standard
Internal Fault/Incorrect Wiring protection	Standard
Common external fault capability	Standard
Field upgradable firmware	Standard

Rating definitions - Optional Standby: Applicable for supplying backup power for the duration of the utility power outage with correct maintenance performed. No overload capability is available for this rating. (All ratings in accordance with BS5514, ISO3046, UL2200, and DIN6271).

\* Maximum kilovolt amps and current are subject to and limited by such factors as fuel BTU/megajoule content, ambient temperature, altitude, engine power and condition, etc. Maximum power decreases approximately 3.5% for each 1,000 ft (304.8 m) above sea level; and also will decrease approximately 1% for each 10 °F (6 °C) above 60 °F (16 °C).

\*\*Sound levels are taken from the front of the generator. Sound levels taken from other sides of the generator may be higher depending on installation parameters.

## 16/20/22 kW

## Switch Options

### Limited Circuits Switch Features

- 16 space, 24 circuit, breakers not included.
- Electrically operated, mechanically-held contacts for fast, positive connections.
- Rated for all classes of load, 100% equipment rated, both inductive and resistive.
- 2-pole, 250 VAC contactors.
- 30 millisecond transfer time.
- Dual coil design.
- Rated for both copper and aluminum conductors.
- Main contacts are silver plated or silver alloy to resist welding and sticking.
- NEMA/UL 3R aluminum outdoor enclosure allows for indoor or outdoor mounting flexibility.
- Multi listed for use with 1 in standard, tandem, GFCI and AFCI breakers from Siemens, Murray, Eaton, and Square D for the most flexible and cost effective install.

### Dimensions

	Height		Width		Depth
	H1	H2	W1	W2	
in	26.75	30.1	10.5	13.5	6.91
cm	67.95	76.45	26.67	34.29	17.55

Wire Ranges		
Conductor Lug	Neutral Lug	Ground Lug
1/0 - #14	2/0 - #14	2/0 - #14

Model	G007036 (16kW)
No. of poles	2
Current rating (amps)	100
Voltage rating (VAC)	120 / 240, 1Ø
Utility voltage monitor (fixed)*	
-Pick-up	80%
-Dropout	65%
Return to Utility*	Approx. 15 sec
Exercises bi-weekly for 5 minutes*	Standard
ETL or UL Listed	Standard
Total circuits available	24
Tandem breaker capabilities	8 tandems
Circuit breaker protected	
Available RMS symmetrical	10,000
Fault current @ 250 volts	

\*Function of Evolution controller  
Exercise can be set to weekly or monthly

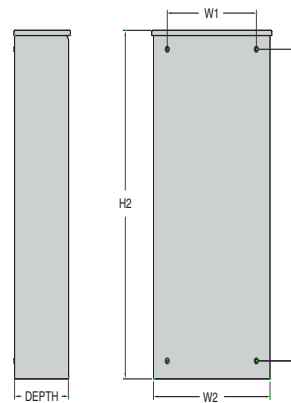

### Service Rated Smart Switch Features

- Includes digital power management technology (DPM) standard.
- Intelligently manages up to four air conditioner loads with no additional hardware.
- Up to eight additional large (240 VAC) loads can be managed when used in conjunction with Smart Management Modules (SMMs).
- Electrically operated, mechanically-held contacts for fast, clean connections.
- Rated for all classes of load, 100% equipment rated, both inductive and resistive.
- 2-pole, 250 VAC contactors.
- Service equipment rated, dual coil design.
- Rated for both aluminum and copper conductors.
- Main contacts are silver plated or silver alloy to resist welding and sticking.
- NEMA/UL 3R aluminum outdoor enclosure allows for indoor or outdoor mounting flexibility.

### Dimensions

	Height		Width		Depth
	H1	H2	W1	W2	
in	26.75	30.1	10.5	13.5	6.91
cm	67.95	76.45	26.67	34.29	17.55

Wire Ranges		
Conductor Lug	Neutral Lug	Ground Lug
350 MCM - #6	350 MCM - #6	2/0 - #14

Model	G007037 (16 kW) / G007039 (20 kW) / G007043 (22 kW)
No. of poles	2
Current rating (amps)	200
Voltage rating (VAC)	120/240, 1Ø
Utility voltage monitor (fixed)*	
-Pick-up	80%
-Dropout	65%
Return to Utility*	Approx. 13 sec
Exercises bi-weekly for 5 minutes*	Standard
ETL or UL listed	Standard
Enclosure type	NEMA/UL 3R
Circuit breaker protected	22,000
Lug range	250 MCM - #6

\*Function of Evolution controller  
Exercise can be set to weekly or monthly

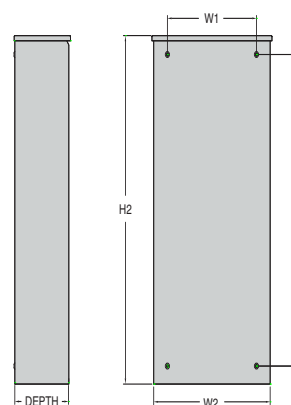

## 16/20/22 kW

## Available Accessories

Model #	Product	Description
G005819-0	26R Wet Cell Battery	Every standby generator requires a battery to start the system. Generac offers the recommended 26R wet cell battery for use with all air-cooled standby product (excluding PowerPact™).
G007101-0	Battery Pad Warmer	Pad warmer rests under the battery. Recommended for use if temperature regularly falls below 0 °F (-18 °C). (Not necessary for use with AGM-style batteries).
G007102-0	Oil Warmer	Oil warmer slips directly over the oil filter. Recommended for use if temperature regularly falls below 0 °F (-18 °C).
G007103-1	Breather Warmer	Breather warmer is for use in extreme cold weather applications. For use with Evolution controllers only in climates where heavy icing occurs.
G005621-0	Auxiliary Transfer Switch Contact Kit	The auxiliary transfer switch contact kit allows the transfer switch to lock out a single large electrical load that may not be needed. Not compatible with 50 amp pre-wired switches.
G007027-0 - Bisque	Fascia Base Wrap Kit	The fascia base wrap snaps together around the bottom of the new air-cooled generators. This offers a sleek, contoured appearance as well as offering protection from rodents and insects by covering the lifting holes located in the base.
G005703-0 - Bisque	Touch-Up Paint Kit	If the generator enclosure is scratched or damaged, it is important to touch up the paint to protect from future corrosion. The touch-up paint kit includes the necessary paint to correctly maintain or touch up a generator enclosure.
G006485-0	Scheduled Maintenance Kit	Generac's scheduled maintenance kit provides all the items necessary to perform complete routine maintenance on a Generac automatic standby generator (oil not included).
G007005-0	Wi-Fi LP Tank Fuel Level Monitor	The Wi-Fi enabled LP tank fuel level monitor provides constant monitoring of the connected LP fuel tank. Monitoring the LP tank's fuel level is an important step in verifying the generator is ready to run during an unexpected power failure. Status alerts are available through a free application to notify users when the LP tank is in need of a refill.
G007000-0 (50 amp) G007006-0 (100 amp)	Smart Management Module	Smart Management Modules (SMM) are used to optimize the performance of a standby generator. They manage large electrical loads upon startup and shed them to aid in recovery when overloaded. In many cases, using SMM's can reduce the overall size and cost of the system.
G007169-0	Mobile Link® 4G LTE Cellular Accessory	The Mobile Link 4G LTE Cellular Accessory allows users to monitor the status of the generator from anywhere in the world, using a smart phone, tablet, or PC. Easily access information such as the current operating status and maintenance alerts. Users can connect an account with an authorized service dealer for fast, friendly, and proactive service. With Mobile Link, users are taken care of before the next power outage.
G007220-0 - Bisque	Base Plug Kit	Base plugs snap into the lifting holes on the base of air-cooled home standby generators. This offers a sleek, contoured appearance, as well as offers protection from rodents and insects by covering the lifting holes located in the base. Kit contains four plugs, sufficient for use on a single air-cooled home standby generator.

## Dimensions &amp; UPCs

Model	UPC
G007035	696471074161
G007036	696471074154
G007037	696471074178
G007038	696471074185
G007039	696471074192
G007042	696471074208
G007043	696471074215

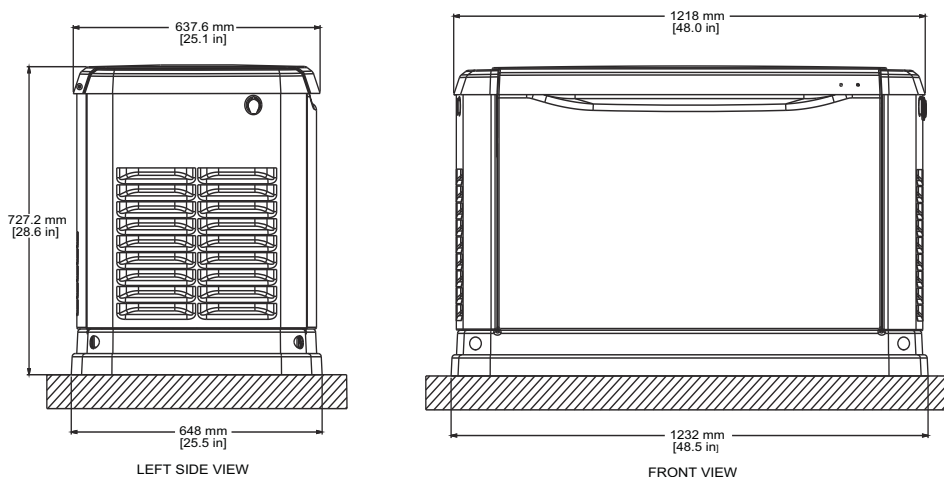

Dimensions shown are approximate. See installation manual for exact dimensions. DO NOT USE THESE DIMENSIONS FOR INSTALLATION PURPOSES.